



ICAO

International Standards
and Recommended Practices

Annex 16 to the Convention on International Civil Aviation

Environmental Protection

Volume II — Aircraft Engine Emissions
Fourth Edition, July 2017



This edition supersedes, on 1 January 2018, all previous editions of Annex 16, Volume II.

For information regarding the applicability of the Standards and Recommended Practices, see the Foreword.

INTERNATIONAL CIVIL AVIATION ORGANIZATION



| ICAO

International Standards
and Recommended Practices

Annex 16 to the Convention on International Civil Aviation

Environmental Protection

Volume II — Aircraft Engine Emissions
Fourth Edition, July 2017

This edition supersedes, on 1 January 2018, all previous editions of Annex 16, Volume II.

For information regarding the applicability of the Standards and Recommended Practices, see the Foreword.

INTERNATIONAL CIVIL AVIATION ORGANIZATION

Published in separate English, Arabic, Chinese, French, Russian
and Spanish editions by the
INTERNATIONAL CIVIL AVIATION ORGANIZATION
999 Robert-Bourassa Boulevard, Montréal, Quebec, Canada H3C 5H7

For ordering information and for a complete listing of sales agents
and booksellers, please go to the ICAO website at www.icao.int

First edition 1981
Second edition 1993
Third edition 2008
Fourth edition 2017

Annex 16 — Environmental Protection
Volume II — Aircraft Engine Emissions

Order Number: AN16-2
ISBN 978-92-9258-314-9

© ICAO 2017

All rights reserved. No part of this publication may be reproduced, stored in a
retrieval system or transmitted in any form or by any means, without prior
permission in writing from the International Civil Aviation Organization.

AMENDMENTS

Amendments are announced in the supplements to the *Products and services Catalogue*; the Catalogue and its supplements are available on the ICAO website at www.icao.int. The space below is provided to keep a record of such amendments.

RECORD OF AMENDMENTS AND CORRIGENDA

AMENDMENTS			
No.	Date applicable	Date entered	Entered by
1-9	Incorporated in this Edition		
10	1/1/21	—	ICAO

CORRIGENDA			
No.	Date of issue	Date entered	Entered by

TABLE OF CONTENTS

	<i>Page</i>
Foreword	<i>(ix)</i>
Part I. DEFINITIONS AND SYMBOLS.....	I-1-1
CHAPTER 1. Definitions	I-1-1
CHAPTER 2. Symbols	I-2-1
Part II. VENTED FUEL	II-1-1
CHAPTER 1. Administration	II-1-1
CHAPTER 2. Prevention of intentional fuel venting.....	II-2-1
Part III. EMISSIONS CERTIFICATION.....	III-1-1
CHAPTER 1. Administration	III-1-1
CHAPTER 2. Turbojet and turbofan engines intended for propulsion only at subsonic speeds.....	III-2-1
2.1 General	III-2-1
2.2 Smoke	III-2-3
2.3 Gaseous emissions	III-2-3
2.4 Information required	III-2-6
CHAPTER 3. Turbojet and turbofan engines intended for propulsion at supersonic speeds	III-3-1
3.1 General	III-3-1
3.2 Smoke	III-3-3
3.3 Gaseous emissions	III-3-3
3.4 Information required	III-3-3
CHAPTER 4. Particulate matter emissions	III-4-1
4.1 General	III-4-1
4.2 Non-volatile particulate matter emissions	III-4-3
4.3 Information required	III-4-4
Part IV. NON-VOLATILE PARTICULATE MATTER ASSESSMENT FOR INVENTORY AND MODELLING PURPOSES	IV-1-1

APPENDICES

APPENDIX 1. Measurement of reference pressure ratio	APP 1-1
1. General	APP 1-1
2. Measurement	APP 1-1
APPENDIX 2. Smoke emission evaluation	APP 2-1
1. Introduction and definitions	APP 2-1
2. Measurement of smoke emissions	APP 2-1
3. Calculation of Smoke Number from measured data	APP 2-6
4. Reporting of data to the certificating authority	APP 2-6
APPENDIX 3. Instrumentation and measurement techniques for gaseous emissions	APP 3-1
1. Introduction	APP 3-1
2. Definitions	APP 3-1
3. Data required	APP 3-2
4. General arrangement of the system	APP 3-3
5. Description of component parts	APP 3-3
6. General test procedures	APP 3-5
7. Calculations	APP 3-7
Attachment A to Appendix 3. Specification for HC analyser	APP 3-13
Attachment B to Appendix 3. Specification for CO and CO ₂ analysers	APP 3-15
Attachment C to Appendix 3. Specification for NO _x analyser	APP 3-17
Attachment D to Appendix 3. Calibration and test gases	APP 3-19
Attachment E to Appendix 3. The calculation of the emissions parameters — basis, measurement corrections and alternative numerical method	APP 3-21
Attachment F to Appendix 3. Specifications for additional data	APP 3-27
APPENDIX 4. Specification for fuel to be used in aircraft turbine engine emission testing	APP 4-1
APPENDIX 5. Instrumentation and measurement techniques for gaseous emissions from afterburning gas turbine engines	APP 5-1
1. Introduction	APP 5-1
2. Definitions	APP 5-1
3. Data required	APP 5-2
4. General arrangement of the system	APP 5-3
5. Description of component parts	APP 5-3
6. General test procedures	APP 5-6
7. Calculations	APP 5-8
Attachment A to Appendix 5. Specification for HC analyser	APP 5-15

	<i>Page</i>
Attachment B to Appendix 5. Specification for CO and CO ₂ analysers	APP 5-17
Attachment C to Appendix 5. Specification for NO _x analyser	APP 5-19
Attachment D to Appendix 5. Calibration and test gases	APP 5-21
Attachment E to Appendix 5. The calculation of the emissions parameters — basis, measurement corrections and alternative numerical method	APP 5-23
Attachment F to Appendix 5. Specifications for additional data	APP 5-29
APPENDIX 6. Compliance procedure for gaseous emissions, smoke and particulate matter emissions	APP 6-1
1. General	APP 6-1
2. Compliance procedures	APP 6-1
3. Procedure in the case of failure	APP 6-3
APPENDIX 7. Instrumentation and measurement techniques for non-volatile particulate matter emissions	APP 7-1
1. Introduction	APP 7-1
2. Definitions, acronyms and symbols	APP 7-1
3. Data required	APP 7-5
4. General arrangement of the nvPM sampling and measurement system	APP 7-5
5. General test procedure	APP 7-9
6. Calculations	APP 7-13
Attachment A to Appendix 7. Requirements and recommendations for nvPM sampling system	APP 7-17
Attachment B to Appendix 7. Specification for nvPM mass instrument and calibration	APP 7-23
Attachment C to Appendix 7. Specifications and calibration for the volatile particle remover and the nvPM number instrument	APP 7-33
Attachment D to Appendix 7. Specifications for additional data	APP 7-37
Attachment E to Appendix 7. Procedures for system operation	APP 7-39
APPENDIX 8. Procedures for estimating non-volatile particulate matter system loss corrections	APP 8-1
1. General	APP 8-1
2. Definition, acronyms, and symbols	APP 8-1
3. Data required	APP 8-4
4. nvPM system loss correction methodology and calculation procedure	APP 8-5
5. Reporting and limitations	APP 8-10
6. Procedure to determine penetration fractions of individual components of the nvPM sampling and measurement system	APP 8-11

FOREWORD

Historical background

In 1972 the United Nations Conference on the Human Environment was held in Stockholm. The position of ICAO at this Conference was developed in Assembly Resolution A18-11 which contained the following clause among others:

- “2. in fulfilling this role ICAO is conscious of the adverse environmental impact that may be related to aircraft activity and its responsibility and that of its member States to achieve maximum compatibility between the safe and orderly development of civil aviation and the quality of the human environment;”

The 18th Assembly also adopted Resolution A18-12 relating to the environment which states:

“THE ASSEMBLY:

1. REQUESTS the Council, with the assistance and co-operation of other bodies of the Organization and other international organizations to continue with vigour the work related to the development of Standards, Recommended Practices and Procedures and/or guidance material dealing with the quality of the human environment;”

This resolution was followed up by the establishment of an ICAO Action Programme Regarding the Environment. As part of this Action Programme a Study Group was established to assist the Secretariat in certain tasks related to aircraft engine emissions. As a result of the work of this Study Group, an ICAO Circular entitled *Control of Aircraft Engine Emissions* (Circular 134) was published in 1977. This Circular contained guidance material in the form of a certification procedure for the control of vented fuel, smoke and certain gaseous emissions for new turbojet and turbofan engines intended for propulsion at subsonic speeds.

It was agreed by the Council that the subject of aircraft engine emissions was not one that was solely confined to objective technical issues but was one that needed consideration by experts in many fields and included the direct views of Member States. A Council committee, known as the Committee on Aircraft Engine Emissions (CAEE) was therefore established in 1977 to pursue a number of aspects of the subject.

At the second meeting of the Committee on Aircraft Engine Emissions, held in May 1980, proposals were made for material to be included in an ICAO Annex. After amendment following the usual consultation with Member States of the Organization, the proposed material was adopted by the Council to form the text of this document. The Council agreed that it was desirable to include all provisions relating to environmental aspects of aviation in one Annex. It therefore renamed Annex 16 as “Environmental Protection”, making the existing text of the Annex into “Volume I — Aircraft Noise”, the material contained in this document becoming “Volume II — Aircraft Engine Emissions”.

Applicability

Part I of Volume II of Annex 16 contains definitions and symbols and Part II contains Standards relating to vented fuel. Part III contains Standards relating to emissions certification applicable to the classes of aircraft engines specified in the individual chapters of the Part, where such engines are fitted to aircraft engaged in international civil aviation. Part IV contains Standards and Recommended Practices for non-volatile particulate matter assessment for inventory and modelling purposes.

Action by Contracting States

Notification of differences. The attention of Contracting States is drawn to the obligation imposed by Article 38 of the Convention by which Contracting States are required to notify the Organization of any differences between their national regulations and practices and the International Standards contained in this Annex and any amendments thereto. Contracting States are invited to extend such notification to any differences from the Recommended Practices contained in this Annex, and any amendments thereto, when the notification of such differences is important for the safety of air navigation. Further, Contracting States are invited to keep the Organization currently informed of any differences which may subsequently occur, or of the withdrawal of any differences previously notified. A specific request for notification of differences will be sent to Contracting States immediately after the adoption of each amendment to this Annex.

The attention of States is also drawn to the provisions of Annex 15 related to the publication of differences between their national regulations and practices and the related ICAO Standards and Recommended Practices through the Aeronautical Information Service, in addition to the obligation of States under Article 38 of the Convention.

Use of the Annex text in national regulations. The Council, on 13 April 1948, adopted a resolution inviting the attention of Contracting States to the desirability of using in their own national regulations, as far as is practicable, the precise language of those ICAO Standards that are of a regulatory character and also of indicating departures from the Standards, including any additional national regulations that were important for the safety or regularity of international air navigation. Wherever possible, the provisions of this Annex have been written in such a way as to facilitate incorporation, without major textual changes, into national legislation.

Status of Annex components

An Annex is made up of the following component parts, not all of which, however, are necessarily found in every Annex; they have the status indicated.

1.— Material comprising the Annex proper:

- a) *Standards and Recommended Practices* adopted by the Council under the provisions of the Convention. They are defined as follows:

Standard: Any specification for physical characteristics, configuration, matériel, performance, personnel or procedure, the uniform application of which is recognized as necessary for the safety or regularity of international air navigation and to which Contracting States will conform in accordance with the Convention; in the event of impossibility of compliance, notification to the Council is compulsory under Article 38.

Recommended Practice: Any specification for physical characteristics, configuration, matériel, performance, personnel or procedure, the uniform application of which is recognized as desirable in the interest of safety, regularity or efficiency of international air navigation, and to which Contracting States will endeavour to conform in accordance with the Convention.

- b) *Appendices* comprising material grouped separately for convenience but forming part of the Standards and Recommended Practices adopted by the Council.
- c) *Provisions* governing the applicability of the Standards and Recommended Practices.
- d) *Definitions* of terms used in the Standards and Recommended Practices which are not self-explanatory in that they do not have accepted dictionary meanings. A definition does not have an independent status but is an essential part of each Standard and Recommended Practice in which the term is used, since a change in the meaning of the term would affect the specification.

- e) *Tables* and *Figures* which add to or illustrate a Standard or Recommended Practice and which are referred to therein, form part of the associated Standard or Recommended Practice and have the same status.

2.— Material approved by the Council for publication in association with the Standards and Recommended Practices:

- a) *Forewords* comprising historical and explanatory material based on the action of the Council and including an explanation of the obligations of States with regard to the application of the Standards and Recommended Practices ensuing from the Convention and the Resolution of Adoption.
- b) *Introductions* comprising explanatory material introduced at the beginning of parts, chapters or sections of the Annex to assist in the understanding of the application of the text.
- c) *Notes* included in the text, where appropriate, to give factual information or references bearing on the Standards or Recommended Practices in question, but not constituting part of the Standards or Recommended Practices.
- d) *Attachments* comprising material supplementary to the Standards and Recommended Practices, or included as a guide to their application.

Disclaimer regarding patents

Attention is drawn to the possibility that certain elements of Standards and Recommended Practices in this Annex may be the subject of patents or other intellectual property rights. ICAO shall not be responsible or liable for not identifying any or all such rights. ICAO takes no position regarding the existence, validity, scope or applicability of any claimed patents or other intellectual property rights, and accepts no responsibility or liability therefore or relating thereto.

Selection of language

This Annex has been adopted in six languages — English, Arabic, Chinese, French, Russian and Spanish. Each Contracting State is requested to select one of those texts for the purpose of national implementation and for other effects provided for in the Convention, either through direct use or through translation into its own national language, and to notify the Organization accordingly.

Editorial practices

The following practice has been adhered to in order to indicate at a glance the status of each statement: *Standards* have been printed in light face roman; *Recommended Practices* have been printed in light face italics, the status being indicated by the prefix **Recommendation**; *Notes* have been printed in light face italics, the status being indicated by the prefix *Note*.

It is to be noted that in the English text the following practice has been adhered to when writing the specifications: Standards employ the operative verb “shall” while Recommended Practices employ the operative verb “should”.

The units of measurement used in this document are in accordance with the International System of Units (SI) as specified in Annex 5 to the Convention on International Civil Aviation. Where Annex 5 permits the use of non-SI alternative units, these are shown in parentheses following the basic units. Where two sets of units are quoted it must not be assumed that the pairs of values are equal and interchangeable. It may, however, be inferred that an equivalent level of safety is achieved when either set of units is used exclusively.

Any reference to a portion of this document which is identified by a number includes all subdivisions of that portion.

Coordination with ISO activity

In the provisions related to certification procedures, use is made of the related specifications developed by the International Organization for Standardization (ISO). In most cases, these specifications have been incorporated by direct reference. However, in some cases, it has been found necessary to modify the specifications to suit ICAO requirements and in such cases the modified material is included in full in this document. The assistance provided by ISO in the development of detailed specifications is recognized.

Table A. Amendments to Annex 16

<i>Amendment</i>	<i>Source(s)</i>	<i>Subject(s)</i>	<i>Adopted Effective Applicable</i>
1st Edition	Special Meeting on Aircraft Noise in the Vicinity of Aerodromes (1969)		2 April 1971 2 August 1971 6 January 1972
1	First Meeting of the Committee on Aircraft Noise	Noise certification of future production and derived versions of subsonic jet aeroplanes and updating of terminology used to describe aircraft weight.	6 December 1972 6 April 1973 16 August 1973
2	Third Meeting of the Committee on Aircraft Noise	Noise certification of light propeller-driven aeroplanes and subsonic jet aeroplanes of 5 700 kg and less maximum certificated take-off weight and guidance on discharge of functions by States in the cases of lease, charter and interchange of aircraft.	3 April 1974 3 August 1974 27 February 1975
3 (2nd Edition)	Fourth Meeting of the Committee on Aircraft Noise	Noise certification standards for future subsonic jet aeroplanes and propeller-driven aeroplanes, other than STOL aeroplanes, and guidelines for noise certification of future supersonic aeroplanes, propeller-driven STOL aeroplanes and installed APU and associated aircraft systems when operating on the ground.	21 June 1976 21 October 1976 6 October 1977
4 (3rd Edition)	Fifth Meeting of the Committee on Aircraft Noise	Introduction of a new parameter, viz. number of engines in the noise certification standards for subsonic jet aeroplanes, improvements in detailed test procedures to ensure that the same level of technology is applied to all types of aircraft, and editorial changes to simplify the language and eliminate inconsistencies.	6 March 1978 6 July 1978 10 August 1978
5 (Annex 16, Volume I — 1st Edition)	Sixth Meeting of the Committee on Aircraft Noise	<ol style="list-style-type: none"> Annex retitled <i>Environmental Protection</i> and to be issued in two volumes as follows: Volume I — <i>Aircraft Noise</i> (incorporating provisions in the third edition of Annex 16 as amended by Amendment 5) and Volume II — <i>Aircraft Engine Emissions</i>. Introduction in Volume I of noise certification Standards for helicopters and for future production of existing SST aeroplanes, updating of guidelines for noise certification of installed APU and associated aircraft systems and editorial amendments including changes to units of measurement to bring the Annex in line with Annex 5 provisions. 	11 May 1981 11 September 1981 26 November 1981
6 (Annex 16, Volume II — 1st Edition)	Second Meeting of the Committee on Aircraft Engine Emissions	Introduction of Volume II containing Standards relating to the control of fuel venting, smoke and gaseous emissions from newly manufactured turbojet and turbofan engines intended for subsonic and supersonic propulsion.	30 June 1981 30 October 1981 18 February 1982

<i>Amendment</i>	<i>Source(s)</i>	<i>Subject(s)</i>	<i>Adopted Effective Applicable</i>
1	First Meeting of the Committee on Aviation Environmental Protection	Changes in test fuel specifications, Appendix 4.	4 March 1988 31 July 1988 17 November 1988
2 (2nd Edition)	Second Meeting of the Committee on Aviation Environmental Protection	a) increased stringency of NOx emissions limits; b) improvements in the smoke and gaseous emissions certification procedure.	24 March 1993 26 July 1993 11 November 1993
3	Third Meeting of the Committee on Aviation Environmental Protection	Amendment of the criteria on calibration and test gases in Appendices 3 and 5.	20 March 1997 20 March 1997
4	Fourth Meeting of the Committee on Aviation Environmental Protection	Increased stringency of NOx emissions limits.	26 February 1999 19 July 1999 4 November 1999
5	Sixth Meeting of the Committee on Aviation Environmental Protection	Increase in stringency of the NOx emissions Standards.	23 February 2005 11 July 2005 24 November 2005
6 (3rd Edition)	Seventh meeting of the Committee on Aviation Environmental Protection	a) clarification of applicable corrections to reference day and reference engine conditions and of the humidity terminology used; b) amendments allowing the use of test fuels outside those specified with certificating authority approval; c) standardization of terminology relating to thrust setting; d) clarification of the appropriate value of fuel flow to be used at each LTO point; and e) amendments to the requirements specifying the materials that may be used in sampling rates.	7 March 2008 20 July 2008 20 November 2008
7	Eighth meeting of the Committee on Aviation Environmental Protection (CAEP/8).	a) increase in stringency of the NOx emissions Standards; b) an update to the references to the <i>Environmental Technical Manual</i> (Doc 9501), Volume II — <i>Procedures for the Emissions Certification of Aircraft Engines</i> ; c) updates to the text to replace “variations in procedures” by “equivalent procedures”, in order to improve consistency and harmonization within Annex 16, Volume II and with the <i>Environmental Technical Manual</i> (Doc 9501), Volume II — <i>Procedures for the Emissions Certification of Aircraft Engines</i> ; d) the format of applicability dates in 2.3.2 made consistent with the convention used in Annex 6 and Annex 16, Volume I; e) improved readability by moving some paragraphs to more appropriate places; and f) minor editorial changes.	4 March 2011 18 July 2011 17 November 2011

<i>Amendment</i>	<i>Source(s)</i>	<i>Subject(s)</i>	<i>Adopted Effective Applicable</i>
8	Ninth meeting of the Committee on Aviation Environmental Protection (CAEP/9)	<ul style="list-style-type: none"> a) amendments to Attachment A to Appendix 3 to update the hydrocarbon (HC) analyser oven temperature range; b) amendments to allow the use of modern instruments for humidity measurement and to update the location of the humidity instrument during emissions certification tests; and c) minor editorial changes associated with terminology, document numbering and typographical changes. 	<ul style="list-style-type: none"> 3 March 2014 14 July 2014 1 January 2015
9 (4th Edition)	Tenth meeting of the Committee on Aviation Environmental Protection (CAEP/10)	<ul style="list-style-type: none"> a) addition of the definition for “type certificate” in Annex 16, Volume II, Part I, Chapter 1; b) clarification of the requirements for the sampling line temperature; c) changes to the calibration gas for the NO_x analyser; d) changes to the naphthalene content for the emissions test fuel specification; e) non-volatile particulate matter (nvPM) engine emissions Standard for turbofan and turbojet engines, with rated thrust greater than 26.7 kN, manufactured from 1 January 2020; f) Annex 16, Volume II consistency with the new nvPM engine emissions Standard; g) correction of minor errors or for consistency. 	<ul style="list-style-type: none"> 3 March 2017 21 July 2017 1 January 2018
10	Eleventh meeting of the Committee on Aviation Environmental Protection (CAEP/11)	<ul style="list-style-type: none"> a) updates to the applicability date provisions for new engine types; b) corrections to flow rate specifications and conditions; c) introduction of generic language for production engines exemptions after the applicability dates of the smoke, NO_x, HC and CO, nvPM mass and number emission Standards; d) new text on CAEP/11 nvPM mass and number engine emissions Standards for new type and in-production engines applicable 1 January 2023; e) consequential changes across Annex 16, Volume II for consistency with the new nvPM mass and number Standard, with the introduction of the end applicability date of 1 January 2023 for the Smoke Number (SN) Standard for engines of rated thrust greater than 26.7 kN; and f) corrections to general technical, nomenclature and typographical issues. 	<ul style="list-style-type: none"> 11 March 2020 20 July 2020 1 January 2021

INTERNATIONAL STANDARDS AND RECOMMENDED PRACTICES

PART I. DEFINITIONS AND SYMBOLS

CHAPTER 1. DEFINITIONS

Where the following expressions are used in Volume II of this Annex, they have the meanings ascribed to them below:

Afterburning. A mode of engine operation wherein a combustion system fed (in whole or part) by vitiated air is used.

Approach phase. The operating phase defined by the time during which the engine is operated in the approach operating mode.

Climb phase. The operating phase defined by the time during which the engine is operated in the climb operating mode.

Date of manufacture. The date of issue of the document attesting that the individual aircraft or engine as appropriate conforms to the requirements of the type or the date of an analogous document.

Derivative version. An aircraft gas turbine engine of the same generic family as an originally type-certificated engine and having features which retain the basic core engine and combustor design of the original model and for which other factors, as judged by the certificating authority, have not changed.

Note.— Attention is drawn to the difference between the definition of “derived version of an aeroplane” in Volume I of Annex 16 and the definition of “derivative version” in this Volume.

Exhaust nozzle. In the exhaust emissions sampling of gas turbine engines where the jet effluxes are not mixed (as in some turbofan engines, for example) the nozzle considered is that for the gas generator (core) flow only. Where, however, the jet efflux is mixed the nozzle considered is the total exit nozzle.

Non-volatile particulate matter (nvPM). Emitted particles that exist at a gas turbine engine exhaust nozzle exit plane that do not volatilize when heated to a temperature of 350°C.

Oxides of nitrogen. The sum of the amounts of the nitric oxide and nitrogen dioxide contained in a gas sample calculated as if the nitric oxide were in the form of nitrogen dioxide.

Rated thrust. For engine emissions purposes, the maximum take-off thrust approved by the certificating authority for use under normal operating conditions at ISA sea level static conditions, and without the use of water injection. Thrust is expressed in kilonewtons.

Reference pressure ratio. The ratio of the mean total pressure at the last compressor discharge plane of the compressor to the mean total pressure at the compressor entry plane when the engine is developing take-off thrust rating in ISA sea level static conditions.

Note.— Methods of measuring reference pressure ratio are given in Appendix 1.

Smoke. The carbonaceous materials in exhaust emissions which obscure the transmission of light.

Smoke Number. The dimensionless term quantifying smoke emissions (see 3 of Appendix 2).

State of Design. The State having jurisdiction over the organization responsible for the type design.

Take-off phase. The operating phase defined by the time during which the engine is operated at the rated thrust.

Taxi/ground idle. The operating phases involving taxi and idle between the initial starting of the propulsion engine(s) and the initiation of the take-off roll and between the time of runway turn-off and final shutdown of all propulsion engine(s).

Type Certificate. A document issued by a Contracting State to define the design of an aircraft, engine or propeller type and to certify that this design meets the appropriate airworthiness requirements of that State.

Note 1.— In some Contracting States a document equivalent to a Type Certificate may be issued for an engine or propeller type.

Note 2.— In some Contracting States the Type Certificate may also certify that the design meets the appropriate aircraft engine emissions requirements of that State.

Unburned hydrocarbons. The total of hydrocarbon compounds of all classes and molecular weights contained in a gas sample, calculated as if they were in the form of methane.

CHAPTER 2. SYMBOLS

Where the following symbols are used in Volume II of this Annex, they have the meanings ascribed to them below:

CO	Carbon monoxide
D_p	The mass of any gaseous pollutant emitted during the reference emissions landing and take-off cycle
F_n	Thrust in International Standard Atmosphere (ISA), sea level conditions, for the given operating mode
F_{oo}	Rated thrust (<i>see</i> definition)
F^*_{oo}	Rated thrust with afterburning applied
HC	Unburned hydrocarbons (<i>see</i> definition)
NO	Nitric oxide
NO ₂	Nitrogen dioxide
NO _x	Oxides of nitrogen (<i>see</i> definition)
nvPM	Non-volatile particulate matter (<i>see</i> definition)
SN	Smoke Number (<i>see</i> definition)
π_{oo}	Reference pressure ratio (<i>see</i> definition)

PART II. VENTED FUEL

CHAPTER 1. ADMINISTRATION

1.1 The provisions of this part shall apply to all turbine engine powered aircraft intended for operation in international air navigation manufactured after 18 February 1982.

1.2 Certification related to the prevention of intentional fuel venting shall be granted by the certifying authority on the basis of satisfactory evidence that either the aircraft or the aircraft engines comply with requirements of Chapter 2.

Note.— The document attesting certification relating to fuel venting may take the form of a separate fuel venting certificate or a suitable statement contained in another document approved by the certifying authority.

1.3 Contracting States shall recognize as valid a certification relating to fuel venting granted by the certifying authority of another Contracting State provided the requirements under which such certification was granted are not less stringent than the provision of Volume II of this Annex.

CHAPTER 2. PREVENTION OF INTENTIONAL FUEL VENTING

Aircraft shall be so designed and constructed as to prevent the intentional discharge into the atmosphere of liquid fuel from the fuel nozzle manifolds resulting from the process of engine shutdown following normal flight or ground operations.

PART III. EMISSIONS CERTIFICATION

CHAPTER 1. ADMINISTRATION

1.1 The provisions of 1.2 to 1.5 shall apply to all engines and their derivative versions included in the classifications defined for emission certification purposes in Chapters 2, 3 and 4 where such engines are fitted to aircraft engaged in international air navigation.

1.2 Emissions certification shall be granted by the certifying authority on the basis of satisfactory evidence that the engine complies with requirements which are at least equal to the stringency of the provisions of Volume II of this Annex. Compliance with the emissions levels of Chapters 2 and 3 shall be demonstrated using the procedure described in Appendix 6.

Note.— The document attesting emissions certification may take the form of a separate emissions certificate or a suitable statement contained in another document approved by the certifying authority.

1.3 The document attesting emissions certification for each individual engine shall include at least the following information which is applicable to the engine type:

- a) name of certifying authority;
- b) manufacturer's type and model designation;
- c) statement of any additional modifications incorporated for the purpose of compliance with the applicable emissions certification requirements;
- d) rated thrust;
- e) reference pressure ratio;
- f) a statement indicating compliance with Smoke Number requirements;
- g) a statement indicating compliance with gaseous pollutant requirements;
- h) a statement indicating compliance with particulate matter requirements.

1.4 Contracting States shall recognize as valid emissions certification granted by the certifying authority of another Contracting State provided that the requirements under which such certification was granted are not less stringent than the provisions of Volume II of this Annex.

1.5 Contracting States shall recognize as valid engine exemptions granted by the competent authority of another Contracting State having jurisdiction over the organization responsible for production of the engine, provided that an acceptable process was used.

Note.— *Guidance on acceptable processes and criteria for granting exemptions is provided in the Environmental Technical Manual (Doc 9501), Volume II — Procedures for the Emissions Certification of Aircraft Engines.*

1.6 Unless otherwise specified in this volume of the Annex, the date to be used by Contracting States in determining the applicability of the Standards in this Annex shall be the date when the application for a Type Certificate for engines of a type or model was submitted to the State of Design, or the date of submission under an equivalent application procedure prescribed by the certifying authority of the State of Design.

1.7 An application for a Type Certificate for engines of a type or model shall be effective for the period specified in the designation of the airworthiness regulations appropriate to the engine of a type or model, except in special cases where the certifying authority accepts an extension of this period. When this period of effectivity is exceeded and an extension is approved, the date to be used in determining the applicability of the Standards in this Annex shall be the date of issue of the Type Certificate or approval of the change in the type design, or the date of issue of approval under an equivalent procedure prescribed by the State of Design, less the period of effectivity.

CHAPTER 2. TURBOJET AND TURBOFAN ENGINES INTENDED FOR PROPULSION ONLY AT SUBSONIC SPEEDS

2.1 General

2.1.1 Applicability

2.1.1.1 The provisions of this chapter shall apply to all turbojet and turbofan engines, as further specified in 2.2 and 2.3, intended for propulsion only at subsonic speeds, except when the certificating authority or the competent authority having jurisdiction over the organization responsible for production of the engine grants exemptions for:

- a) specific engine types and derivative versions of such engines for which the Type Certificate of the first basic type was issued or other equivalent prescribed procedure was carried out before 1 January 1965;
- b) a limited number of engines over a specific period of time beyond the dates of applicability specified in 2.2 and 2.3 for the manufacture of the individual engine.

2.1.1.2 In such cases, an exemption document shall be issued by the certificating authority or the competent authority having jurisdiction over the organization responsible for production of the engines, the identification plates on the engines shall be marked “EXEMPT” and the grant of exemption shall be noted in the permanent engine record. The certificating authority or the competent authority having jurisdiction over the organization responsible for production of the engines shall take into account the numbers of exempted engines that will be produced and their impact on the environment. Exemptions shall be reported by engine serial number and made available via an official public register.

Recommendation.— *When such an exemption is granted, the certificating authority or the competent authority having jurisdiction over the organization responsible for production of the engines should consider imposing a time limit on the production of such engines.*

Note.— *Further guidance on issuing exemptions is provided in the Environmental Technical Manual (Doc 9501), Volume II — Procedures for the Emissions Certification of Aircraft Engines.*

2.1.1.3 The provisions of this chapter shall also apply to engines designed for applications that otherwise would have been fulfilled by turbojet and turbofan engines and which are designed as an integrated propulsive power plant and certified with a rated thrust.

Note.— *Guidance material is provided in the Environmental Technical Manual (Doc 9501), Volume II — Procedures for the Emissions Certification of Aircraft Engines.*

2.1.2 Emissions involved

The following emissions shall be controlled for certification of aircraft engines:

Smoke

Gaseous emissions

Unburned hydrocarbons (HC);

Carbon monoxide (CO); and

Oxides of nitrogen (NO_x).

2.1.3 Units of measurement

2.1.3.1 The smoke emission shall be measured and reported in terms of Smoke Number (SN).

2.1.3.2 The mass (D_p) of the gaseous pollutant HC, CO or NO_x emitted during the reference emissions landing and take-off (LTO) cycle, defined in 2.1.4.2 and 2.1.4.3, shall be measured and reported in grams.

2.1.4 Reference conditions

2.1.4.1 Atmospheric conditions

The reference atmospheric conditions for engine performance shall be ISA at sea level except that the reference humidity shall be 0.00634 kg water/kg dry air.

2.1.4.2 Thrust settings

The engine shall be tested at sufficient thrust settings to define the gaseous and smoke emissions of the engine so that mass emission rates and Smoke Numbers can be determined at the following specific percentages of rated thrust as agreed by the certificating authority:

<i>LTO operating mode</i>	<i>Thrust setting</i>
Take-off	100 per cent F_{oo}
Climb	85 per cent F_{oo}
Approach	30 per cent F_{oo}
Taxi/ground idle	7 per cent F_{oo}

2.1.4.3 Reference emissions landing and take-off (LTO) cycle

The reference emissions LTO cycle for the calculation and reporting of gaseous emissions shall be represented by the following time in each operating mode.

<i>LTO operating mode</i>	<i>Time in operating mode, minutes</i>
Take-off	0.7
Climb	2.2
Approach	4.0
Taxi/ground idle	26.0

2.1.4.4 Fuel specifications

The fuel used during tests shall meet the specifications of Appendix 4.

2.1.5 Test conditions

2.1.5.1 The tests shall be made with the engine on its test bed.

2.1.5.2 The engine shall be representative of the certificated configuration (*see* Appendix 6); off-take bleeds and accessory loads other than those necessary for the engine's basic operation shall not be simulated.

2.1.5.3 When test conditions differ from the reference atmospheric conditions in 2.1.4.1, the gaseous emissions test results shall be corrected to the reference atmospheric conditions in accordance with the procedures of Appendix 3.

2.2 Smoke

2.2.1 Applicability

The provisions of 2.2.2 shall apply:

- a) to engines whose date of manufacture is on or after 1 January 1983 and before 1 January 2023; and
- b) to engines with a maximum rated thrust of less than or equal to 26.7 kN whose date of manufacture is on or after 1 January 2023.

2.2.2 Regulatory Smoke Number

The Smoke Number at any of the four LTO operating mode thrust settings when measured and computed in accordance with the procedures of Appendix 2, or equivalent procedures as agreed by the certifying authority, and converted to a characteristic level by the procedures of Appendix 6 shall not exceed the level determined from the following formula:

$$\text{Regulatory Smoke Number} = 83.6 (F_{oo})^{-0.274} \\ \text{or a value of 50, whichever is lower}$$

Note.— *Guidance material on the definition and the use of equivalent procedures is provided in the Environmental Technical Manual (Doc 9501), Volume II — Procedures for the Emissions Certification of Aircraft Engines.*

2.3 Gaseous emissions

2.3.1 Applicability

The provisions of 2.3.2 shall apply to engines whose rated thrust is greater than 26.7 kN and whose date of manufacture is on or after 1 January 1986 and as further specified for oxides of nitrogen.

2.3.2 Regulatory levels

Gaseous emission levels when measured and computed in accordance with the procedures of Appendix 3 and converted to characteristic levels by the procedures of Appendix 6, or equivalent procedures as agreed by the certifying authority, shall not exceed the regulatory levels determined from the following formulas:

Hydrocarbons (HC): $D_p/F_{oo} = 19.6$

Carbon monoxide (CO): $D_p/F_{oo} = 118$

Oxides of nitrogen (NO_x):

- a) for engines of a type or model for which the date of manufacture of the first individual production model was before 1 January 1996 and for which the date of manufacture of the individual engine was before 1 January 2000:

$$D_p/F_{oo} = 40 + 2\pi_{oo}$$

- b) for engines of a type or model for which the date of manufacture of the first individual production model was on or after 1 January 1996 or for which the date of manufacture of the individual engine was on or after 1 January 2000:

$$D_p/F_{oo} = 32 + 1.6\pi_{oo}$$

- c) for engines of a type or model for which the date of manufacture of the first individual production model was on or after 1 January 2004:

- 1) for engines with a pressure ratio of 30 or less:

- i) for engines with a maximum rated thrust of more than 89.0 kN:

$$D_p/F_{oo} = 19 + 1.6\pi_{oo}$$

- ii) for engines with a maximum rated thrust of more than 26.7 kN but not more than 89.0 kN:

$$D_p/F_{oo} = 37.572 + 1.6\pi_{oo} - 0.2087F_{oo}$$

- 2) for engines with a pressure ratio of more than 30 but less than 62.5:

- i) for engines with a maximum rated thrust of more than 89.0 kN:

$$D_p/F_{oo} = 7 + 2.0\pi_{oo}$$

- ii) for engines with a maximum rated thrust of more than 26.7 kN but not more than 89.0 kN:

$$D_p/F_{oo} = 42.71 + 1.4286\pi_{oo} - 0.4013F_{oo} + 0.00642\pi_{oo} \times F_{oo}$$

- 3) for engines with a pressure ratio of 62.5 or more:

$$D_p/F_{oo} = 32 + 1.6\pi_{oo}$$

- d) for engines of a type or model for which the date of manufacture of the first individual production model was on or after 1 January 2008 or for which the date of manufacture of the individual engine was on or after 1 January 2013:

- 1) for engines with a pressure ratio of 30 or less:

- i) for engines with a maximum rated thrust of more than 89.0 kN:

$$D_p/F_{oo} = 16.72 + 1.4080\pi_{oo}$$

- ii) for engines with a maximum rated thrust of more than 26.7 kN but not more than 89.0 kN:

$$D_p / F_{oo} = 38.5486 + 1.6823\pi_{oo} - 0.2453F_{oo} - 0.00308\pi_{oo}F_{oo}$$

- 2) for engines with a pressure ratio of more than 30 but less than 82.6:

- i) for engines with a maximum rated thrust of more than 89.0 kN:

$$D_p / F_{oo} = -1.04 + 2.0\pi_{oo}$$

- ii) for engines with a maximum rated thrust of more than 26.7 kN but not more than 89.0 kN:

$$D_p / F_{oo} = 46.1600 + 1.4286\pi_{oo} - 0.5303F_{oo} + 0.00642\pi_{oo}F_{oo}$$

- 3) for engines with a pressure ratio of 82.6 or more:

$$D_p / F_{oo} = 32 + 1.6\pi_{oo}$$

- e) for engines of a type or model for which the date of manufacture of the first individual production model was on or after 1 January 2014 and for which an application for a Type Certificate was submitted before 1 January 2023:

- 1) for engines with a pressure ratio of 30 or less:

- i) for engines with a maximum rated thrust of more than 89.0 kN:

$$D_p / F_{oo} = 7.88 + 1.4080\pi_{oo}$$

- ii) for engines with a maximum rated thrust of more than 26.7 kN but not more than 89.0 kN:

$$D_p / F_{oo} = 40.052 + 1.5681\pi_{oo} - 0.3615F_{oo} - 0.0018\pi_{oo}F_{oo}$$

- 2) for engines with a pressure ratio of more than 30 but less than 104.7:

- i) for engines with a maximum rated thrust of more than 89.0 kN:

$$D_p / F_{oo} = -9.88 + 2.0\pi_{oo}$$

- ii) for engines with a maximum rated thrust of more than 26.7 kN but not more than 89.0 kN:

$$D_p / F_{oo} = 41.9435 + 1.505\pi_{oo} - 0.5823F_{oo} + 0.005562\pi_{oo} F_{oo}$$

- 3) for engines with a pressure ratio of 104.7 or more:

$$D_p / F_{oo} = 32 + 1.6\pi_{oo}$$

- f) for engines of a type or model for which an application for a Type Certificate was submitted on or after 1 January 2023:

- 1) for engines with a pressure ratio of 30 or less:

- i) for engines with a maximum rated thrust of more than 89.0 kN:

$$D_p / F_{oo} = 7.88 + 1.4080\pi_{oo}$$

- ii) for engines with a maximum rated thrust of more than 26.7 kN but not more than 89.0 kN:

$$D_p / F_{oo} = 40.052 + 1.5681\pi_{oo} - 0.3615F_{oo} - 0.0018\pi_{oo}F_{oo}$$

- 2) for engines with a pressure ratio of more than 30 but less than 104.7:

- i) for engines with a maximum rated thrust of more than 89.0 kN:

$$D_p / F_{oo} = -9.88 + 2.0\pi_{oo}$$

- ii) for engines with a maximum rated thrust of more than 26.7 kN but not more than 89.0 kN:

$$D_p / F_{oo} = 41.9435 + 1.505\pi_{oo} - 0.5823F_{oo} + 0.005562\pi_{oo} F_{oo}$$

- 3) for engines with a pressure ratio of 104.7 or more:

$$D_p / F_{oo} = 32 + 1.6\pi_{oo}$$

Note.— Guidance material on the definition and the use of equivalent procedures is provided in the Environmental Technical Manual (Doc 9501), Volume II — Procedures for the Emissions Certification of Aircraft Engines.

2.4 Information required

Note.— The information required is divided into three groups: 1) general information to identify the engine characteristics, the fuel used and the method of data analysis; 2) the data obtained from the engine test(s); and 3) the results derived from the test data.

2.4.1 General information

The following information shall be provided for each engine type for which emissions certification is sought:

- a) engine identification;
- b) rated thrust (kN);
- c) reference pressure ratio;
- d) fuel specification reference;
- e) fuel hydrogen/carbon ratio;
- f) the methods of data acquisition;
- g) the method of making corrections for ambient conditions; and
- h) the method of data analysis.

2.4.2 Test information

The following information shall be provided for each engine tested for certification purposes at each of the thrust settings specified in 2.1.4.2. The information shall be provided after correction to the reference ambient conditions where applicable:

- a) fuel flow (kg/s);
- b) emission index (grams/kg) for each gaseous pollutant; and
- c) measured Smoke Number.

2.4.3 Derived information

2.4.3.1 The following derived information shall be provided for each engine tested for certification purposes:

- a) emission rate, i.e. emission index \times fuel flow, (grams/s) for each gaseous pollutant;
- b) total gross emission of each gaseous pollutant measured over the LTO cycle (grams);
- c) values of D_p/F_{oo} for each gaseous pollutant (grams/kN); and
- d) maximum Smoke Number.

2.4.3.2 The characteristic Smoke Number and gaseous pollutant emission levels shall be provided for each engine type for which emissions certification is sought.

CHAPTER 3. TURBOJET AND TURBOFAN ENGINES INTENDED FOR PROPULSION AT SUPERSONIC SPEEDS

3.1 General

3.1.1 Applicability

The provisions of this chapter shall apply to all turbojet and turbofan engines intended for propulsion at supersonic speeds whose date of manufacture is on or after 18 February 1982.

3.1.2 Emissions involved

The following emissions shall be controlled for certification of aircraft engines:

Smoke

Gaseous emissions

Unburned hydrocarbons (HC);

Carbon monoxide (CO); and

Oxides of nitrogen (NO_x).

3.1.3 Units of measurement

3.1.3.1 The smoke emission shall be measured and reported in terms of Smoke Number (SN).

3.1.3.2 The mass (D_p) of the gaseous pollutants HC, CO, or NO_x emitted during the reference emissions landing and take-off (LTO) cycle, defined in 3.1.5.2 and 3.1.5.3 shall be measured and reported in grams.

3.1.4 Nomenclature

Throughout this chapter, where the expression F_{oo}^* is used, it shall be replaced by F_{oo} for engines which do not employ afterburning. For taxi/ground idle thrust setting, F_{oo} shall be used in all cases.

3.1.5 Reference conditions

3.1.5.1 Atmospheric conditions

The reference atmospheric conditions shall be ISA at sea level except that the reference absolute humidity shall be 0.00634 kg water/kg dry air.

3.1.5.2 Thrust settings

The engine shall be tested at sufficient thrust settings to define the gaseous and smoke emissions of the engine so that mass emission rates and Smoke Numbers corrected to the reference ambient conditions can be determined at the following specific percentages of rated thrust as agreed by the certificating authority.

<i>Operating mode</i>	<i>Thrust setting</i>
Take-off	100 per cent F_{oo}^*
Climb	65 per cent F_{oo}^*
Descent	15 per cent F_{oo}^*
Approach	34 per cent F_{oo}^*
Taxi/ground idle	5.8 per cent F_{oo}

3.1.5.3 Reference emissions landing and take-off (LTO) cycle

The reference emissions LTO cycle for the calculation and reporting of gaseous emissions shall be represented by the following time in each operating mode.

<i>LTO operating mode</i>	<i>Time in operating mode, minutes</i>
Take-off	1.2
Climb	2.0
Descent	1.2
Approach	2.3
Taxi/ground idle	26.0

3.1.5.4 Fuel specifications

The fuel used during tests shall meet the specifications of Appendix 4. Additives used for the purpose of smoke suppression (such as organo-metallic compounds) shall not be present.

3.1.6 Test conditions

3.1.6.1 The tests shall be made with the engine on its test bed.

3.1.6.2 The engine shall be representative of the certificated configuration (*see* Appendix 6); off-take bleeds and accessory loads other than those necessary for the engine's basic operation shall not be simulated.

3.1.6.3 Measurements made for determination of emission levels at the thrusts specified in 3.1.5.2 shall be made with the afterburner operating at the level normally used, as applicable.

3.1.6.4 When test conditions differ from the reference conditions in 3.1.5, the test results shall be corrected to the reference conditions in accordance with the procedures of Appendix 5.

3.2 Smoke

3.2.1 Regulatory Smoke Number

The Smoke Number at any thrust setting when measured and computed in accordance with the procedures of Appendix 2 and converted to a characteristic level by the procedures of Appendix 6 shall not exceed the regulatory level determined from the following formula:

$$\text{Regulatory Smoke Number} = 83.6 (F_{oo}^*)^{-0.274}$$

or a value of 50, whichever is lower

Note.— *Certificating authorities may alternatively accept values determined using afterburning provided that the validity of these data is adequately demonstrated.*

3.3 Gaseous emissions

3.3.1 Regulatory levels

Gaseous emission levels when measured and computed in accordance with the procedures of Appendix 3 or Appendix 5, as applicable, and converted to characteristic levels by the procedures of Appendix 6 shall not exceed the regulatory levels determined from the following formulas:

$$\text{Hydrocarbons (HC): } D_p/F_{oo}^* = 140(0.92)^{\pi_{oo}}$$

$$\text{Carbon monoxide (CO): } D_p/F_{oo}^* = 4\,550(\pi_{oo})^{-1.03}$$

$$\text{Oxides of nitrogen (NOx): } D_p/F_{oo}^* = 36 + 2.42\pi_{oo}$$

Note.— *The characteristic level of the Smoke Number or gaseous pollutant emissions is the mean of the values of all the engines tested, measured and corrected to the reference standard engine and reference ambient conditions, divided by the coefficient corresponding to the number of engines tested, as shown in Appendix 6.*

3.4 Information required

Note.— *The information required is divided into three groups: 1) general information to identify the engine characteristics, the fuel used and the method of data analysis; 2) the data obtained from the engine test(s); and 3) the results derived from the test data.*

3.4.1 The following information shall be provided for each engine type for which emissions certification is sought:

- a) engine identification;
- b) rated thrust (kN);
- c) rated thrust with afterburning applied, if applicable (kN);

- d) reference pressure ratio;
- e) fuel specification reference;
- f) fuel hydrogen/carbon ratio;
- g) the methods of data acquisition;
- h) the method of making corrections for ambient conditions; and
- i) the method of data analysis.

3.4.2 Test information

The following information shall be provided for each engine tested for certification purposes at each of the thrust settings specified in 3.1.5.2. The information shall be provided after correction to the reference ambient conditions where applicable:

- a) fuel flow (kg/s);
- b) emission index (grams/kg) for each gaseous pollutant;
- c) percentage of thrust contributed by afterburning; and
- d) measured Smoke Number.

3.4.3 Derived information

3.4.3.1 The following derived information shall be provided for each engine tested for certification purposes:

- a) emission rate, i.e. emission index \times fuel flow, (grams/s), for each gaseous pollutant;
- b) total gross emission of each gaseous pollutant measured over the LTO cycle (grams);
- c) values of D_p/F^*_{oo} for each gaseous pollutant (grams/kN); and
- d) maximum Smoke Number.

3.4.3.2 The characteristic Smoke Number and gaseous pollutant emission levels shall be provided for each engine type for which emissions certification is sought.

Note.— The characteristic level of the Smoke Number or gaseous pollutant emissions is the mean of the values of all the engines tested, measured and corrected to the reference standard engine and reference ambient conditions, divided by the coefficient corresponding to the number of engines tested, as shown in Appendix 6.

CHAPTER 4. PARTICULATE MATTER EMISSIONS

4.1 General

4.1.1 Applicability

4.1.1.1 The provisions of this chapter shall apply to all aircraft engines, as further specified in 4.2, intended for propulsion only at subsonic speeds.

4.1.1.2 Specific provisions for the relevant engine categories shall apply as detailed in section 4.2, except when the certificating authority or the competent authority having jurisdiction over the organization responsible for production of the engines grants exemptions for a limited number of engines over a specific period of time beyond the dates of applicability specified in 4.2 for the manufacture of the individual engine.

4.1.1.3 In such cases, an exemption document shall be issued by the certificating authority or the competent authority having jurisdiction over the organization responsible for production of the engines, the identification plates on the engines shall be marked “EXEMPT” and the grant of exemption shall be noted in the permanent engine record. The certificating authority or the competent authority having jurisdiction over the organization responsible for production of the engines shall take into account the number of exempted engines that will be produced and their impact on the environment. Exemptions shall be reported by engine serial number and made available via an official public register.

Recommendation.— *When such an exemption is granted, the certificating authority or the competent authority having jurisdiction over the organization responsible for production of the engines should consider imposing a time limit on the production of such engines.*

Note.— *Further guidance on issuing exemptions is provided in the Environmental Technical Manual (Doc 9501), Volume II — Procedures for the Emissions Certification of Aircraft Engines.*

4.1.2 Emissions involved

The purpose of this section is to control non-volatile particulate matter mass (nvPM) emissions.

4.1.3 Units of measurement

4.1.3.1 The concentration of nvPM mass shall be measured and reported in micrograms/m³.

4.1.3.2 The nvPM mass emitted during the reference emissions landing and take-off (LTO) cycle, defined in 4.1.4.2 (LTO_{mass}), shall be measured and reported in milligrams.

4.1.3.3 The nvPM number emitted during the reference emissions landing and take-off (LTO) cycle, defined in 4.1.4.2 (LTO_{num}), shall be measured and reported in number of particles.

4.1.4 Reference conditions

4.1.4.1 Atmospheric conditions

The reference atmospheric conditions for the reference standard engine shall be ISA at sea level except that the reference humidity shall be 0.00634 kg water/kg dry air.

4.1.4.2 Reference emissions landing and take-off (LTO) cycle

The engine shall be tested at sufficient thrust settings to define the nvPM emissions of the engine so that nvPM mass emission indices (EI_{mass}) and nvPM number emission indices (EI_{num}) can be determined at the reference emissions LTO cycle thrust settings and at thrusts producing maximum nvPM mass concentration, maximum EI_{mass} and maximum EI_{num} as agreed by the certificating authority.

For the calculation and reporting of nvPM emissions, the reference emissions LTO cycle shall be represented by the following thrust setting and time in each following operating mode:

<i>LTO operating mode</i>	<i>Thrust setting Per cent F_{00}</i>	<i>Time in operating mode Minutes</i>
Take-off	100	0.7
Climb	85	2.2
Approach	30	4.0
Taxi/ground idle	7	26.0

4.1.4.3 Fuel specifications

The fuel used during tests shall meet the specifications of Appendix 4.

4.1.5 Test conditions

4.1.5.1 The tests shall be made with the engine on its test bed.

4.1.5.2 The engine shall be representative of the certificated configuration (*see* Appendix 6); off-take bleeds and accessory loads other than those necessary for the engine's basic operation shall not be simulated.

4.1.5.3 When test conditions differ from the reference atmospheric conditions in 4.1.4.1, EI_{mass} and EI_{num} shall be corrected to the engine combustor inlet temperature under the reference atmospheric conditions in accordance with the procedures of Appendix 7.

4.1.5.4 The maximum nvPM mass concentration shall be corrected for dilution and thermophoretic losses in the Collection Part of the sampling system in accordance with the procedures of Appendix 7. The EI_{mass} and EI_{num} shall be corrected for thermophoretic losses in the Collection Part of the sampling system and fuel composition in accordance with the procedures of Appendix 7.

4.2 Non-volatile particulate matter emissions

4.2.1 Applicability

4.2.1.1 The provisions further specified in 4.2.2 and 4.2.3 shall apply to all turbofan and turbojet engines of a type or model with a rated thrust greater than 26.7 kN.

4.2.1.2 The provisions of this chapter shall also apply to engines designed for applications that otherwise would have been fulfilled by turbojet and turbofan engines and which are designed as an integrated propulsive powerplant and certified with a rated thrust.

4.2.2 Regulatory levels

4.2.2.1 Maximum nvPM mass concentration

For an engine whose date of manufacture of the individual engine is on or after 1 January 2020, the maximum nvPM mass concentration obtained from measurement at sufficient thrust settings, in such a way that the emission maximum can be determined, and computed in accordance with the procedures of Appendix 7 and converted to characteristic levels by the procedures of Appendix 6, or equivalent procedures as agreed by the certifying authority, shall not exceed the regulatory level determined from the following formula:

$$\text{Regulatory limit of nvPM mass concentration} = 10^{(3 + 2.9 F_{oo}^{-0.274})}$$

Note.— Since there is a correlation between nvPM mass concentration and Smoke Number, the regulatory level in 4.2.2.1 was derived from the Smoke Number regulatory level. Further information is provided in the Environmental Technical Manual (Doc 9501), Volume II — Procedures for the Emissions Certification of Aircraft Engines.

4.2.2.2 nvPM mass and nvPM number emitted during the reference LTO cycle

The nvPM mass and nvPM number emission levels when measured and computed in accordance with the procedures of Appendix 7 and converted to characteristic levels by the procedures of Appendix 6, or equivalent procedures as agreed by the certifying authority, shall not exceed the regulatory levels determined from the following formulas:

a) LTO_{mass} :

- 1) for engines of a type or model for which the date of manufacture of the individual engine was on or after 1 January 2023:

- i) for engines with a maximum rated thrust of more than 200 kN:

$$LTO_{mass}/F_{oo} = 347.5$$

- ii) for engines with a maximum rated thrust of more than 26.7 kN but not more than 200 kN:

$$LTO_{mass}/F_{oo} = 4646.9 - 21.497F_{oo}$$

2) for engines of a type or model for which an application for a Type Certificate was submitted on or after 1 January 2023:

i) for engines with a maximum rated thrust of more than 150 kN:

$$LTO_{mass}/F_{oo} = 214.0$$

ii) for engines with a maximum rated thrust of more than 26.7 kN but not more than 150 kN:

$$LTO_{mass}/F_{oo} = 1251.1 - 6.914F_{oo}$$

b) LTO_{num} :

1) for engines of a type or model for which the date of manufacture of the individual engine was on or after 1 January 2023:

i) for engines with a maximum rated thrust of more than 200 kN:

$$LTO_{num}/F_{oo} = 4.170 \times 10^{15}$$

ii) for engines with a maximum rated thrust of more than 26.7 kN but not more than 200 kN:

$$LTO_{num}/F_{oo} = 2.669 \times 10^{16} - 1.126 \times 10^{14}F_{oo}$$

2) for engines of a type or model for which an application for a Type Certificate was submitted on or after 1 January 2023:

i) for engines with a maximum rated thrust of more than 150 kN:

$$LTO_{num}/F_{oo} = 2.780 \times 10^{15}$$

ii) for engines with a maximum rated thrust of more than 26.7 kN but not more than 150 kN:

$$LTO_{num}/F_{oo} = 1.490 \times 10^{16} - 8.080 \times 10^{13}F_{oo}$$

4.2.3 Reporting requirement

The manufacturer shall report the following values of nvPM emissions measured and computed in accordance with the procedures of Appendix 7, or any equivalent procedures as agreed by the certificating authority:

a) maximum EI_{mass} (milligrams/kg of fuel); and

b) maximum EI_{num} (particles/kg of fuel).

4.3 Information required

Note.— The information required is divided into three groups: 1) general information to identify the engine characteristics, the fuel used and the method of data analysis; 2) the data obtained from the engine test(s); and 3) derived information.

4.3.1 General information

The following information shall be provided for each engine type for which emissions certification is sought:

- a) engine identification;
- b) rated thrust (kN);
- c) reference pressure ratio;
- d) fuel specification reference;
- e) fuel hydrogen/carbon ratio;
- f) the methods of data acquisition; and
- g) the method of data analysis.

4.3.2 Test information

4.3.2.1 The following information shall be provided for each engine tested for certification purposes:

- a) fuel net heat of combustion (MJ/kg);
- b) fuel hydrogen content (mass %);
- c) fuel total aromatics content (volume %);
- d) fuel naphthalenes content (volume %); and
- e) fuel sulphur content (ppm by mass).

4.3.2.2 The following information, as measured and computed in accordance with the procedures of Appendix 7, or any equivalent procedures as agreed by the certifying authority, shall be provided for each engine tested for certification purposes:

- a) fuel flow (kg/s) at each thrust setting of the LTO cycle;
- b) EI_{mass} (milligrams/kg of fuel) at each thrust setting of the LTO cycle;
- c) EI_{num} (particles/kg of fuel) at each thrust setting of the LTO cycle.

4.3.3 Derived information

4.3.3.1 The following derived information shall be provided for each engine tested for certification purposes:

- a) emission rate, i.e. $EI_{\text{mass}} \times \text{fuel flow}$, (milligrams/s) for nvPM mass;
- b) emissions rate, i.e. $EI_{\text{num}} \times \text{fuel flow}$, (particles/s) for nvPM number;

- c) total gross emission of nvPM mass measured over the LTO cycle (milligrams);
- d) total gross emission of nvPM number measured over the LTO cycle (particles);
- e) values of LTO_{mass}/F_{oo} (milligrams/kN);
- f) values of LTO_{num}/F_{oo} (particles/kN); and
- g) maximum nvPM mass concentration (micrograms/m³).

4.3.3.2 The characteristic levels shall be provided for the maximum nvPM mass concentration, the LTO_{mass}/F_{oo} and the LTO_{num}/F_{oo} for each engine type for which emissions certification is sought.

PART IV. NON-VOLATILE PARTICULATE MATTER ASSESSMENT FOR INVENTORY AND MODELLING PURPOSES

Note 1.— The purpose of this part is to provide Standard and Recommended Practices on how to calculate the nvPM mass and number correction factors for the nvPM system losses other than the Collection Part thermophoretic losses. The nvPM sampling and measurement system, the Collection Part and the thermophoretic losses calculation are described in Appendix 7.

Note 2.— The nvPM mass and number system loss correction factors permit an estimation of the concentration of the nvPM mass and number at the exhaust of the aircraft engine from the nvPM mass and number concentration obtained in accordance with the procedures of Appendix 7.

For engines of a type or model subject to Part III, Chapter 4, and for which the date of manufacture of the individual engine was on or after 1 January 2023, the nvPM mass and nvPM number system loss correction factors (k_{SL_mass} and k_{SL_num}), and EI_{mass} and EI_{num} corrected for system losses shall be reported to the certificating or competent authority as designated by the State in accordance with the procedures of Appendix 8, or equivalent procedures as agreed by the certificating authority.

Recommendation.— *For inventory and modelling purposes, the nvPM mass and nvPM number emissions obtained in accordance with the procedures of Appendix 7 should be corrected for system losses using the methodology described in Appendix 8.*

APPENDIX 1. MEASUREMENT OF REFERENCE PRESSURE RATIO

1. GENERAL

1.1 Pressure ratio shall be established using a representative engine.

1.2 Reference pressure ratio shall be derived by correlating measured pressure ratio with engine thrust corrected to standard day ambient pressure and entering this correlation at the standard day rated take-off thrust.

2. MEASUREMENT

2.1 Total pressure shall be measured at the last compressor discharge plane and the first compressor front face by positioning at least four probes so as to divide the air flow area into four equal sectors and taking a mean of the four values obtained.

Note.— Compressor discharge total pressure may be obtained from total or static pressure measured at a position as close as possible to the compressor discharge plane. However, the certifying authority may approve alternative means of estimating the compressor discharge total pressure if the engine is so designed that the provision of the probes referred to above is impractical for the emissions test.

2.2 Necessary correlation factors shall be determined during type certification testing using a minimum of one engine and any associated engine component tests and analysis.

2.3 Procedures shall be acceptable to the certifying authority.

APPENDIX 2. SMOKE EMISSION EVALUATION

1. INTRODUCTION AND DEFINITIONS

Note.— The procedures specified in this appendix are concerned with the acquisition of representative exhaust samples and their transmission to, and analysis by, the emissions measuring system.

1.1 Any equivalent procedures to those contained in this appendix shall only be allowed after prior application to and approval by the certifying authority.

1.2 Where the following expressions and symbols are used in this appendix, they have the meanings ascribed to them below:

Sample reference size. The sample mass, 16.2 kg/m² of stained filter area, which if passed through the filter material results in a change of reflectance which gives a value of the SN parameter.

Sample size. A chosen exhaust sample, the magnitude of whose mass (expressed in kilograms per square metre of stained filter surface area) lies in the range prescribed in 2.5.3 h) of this appendix which, when passed through the filter material, causes a change in reflectance yielding a value for the SN parameter.

Sample volume. The chosen sample volume (expressed in cubic metres) whose equivalent mass, calculated as indicated in 3 of this appendix, conforms to the above definition of sampling size.

SN Smoke Number; Dimension less term quantifying smoke emission level based upon the staining of a filter by the reference mass of exhaust gas sample, and rated on a scale of 0 to 100 (see 3 of this appendix).

SN' Smoke Number obtained from an individual smoke sample, not necessarily of the sample reference size, as defined in 3 of this appendix.

W Mass of individual exhaust gas smoke sample, in kilograms, calculated from the measurements of sample volume, pressure and temperature (see 3 of this appendix).

2. MEASUREMENT OF SMOKE EMISSIONS

2.1 Sampling probe for smoke emissions

The sampling probe shall meet the following requirements:

- a) The probe material with which the exhaust emission sample is in contact shall be stainless steel or any other non-reactive material.
- b) If a sampling probe with multiple sampling orifices is used:
 - 1) all sampling orifices shall be of equal diameter; and
 - 2) the sampling probe design shall be such that at least 80 per cent of the pressure drop through the probe assembly is taken at the orifices.

- c) The number of locations sampled shall not be less than 12.
- d) The sampling plane shall be as close to the engine exhaust nozzle exit plane as permitted by considerations of engine performance but in any case shall be within 0.5 nozzle diameters of the exit plane.
- e) The applicant shall provide evidence to the certificating authority, by means of detailed traverses, that the proposed probe design and position does provide a representative sample for each prescribed thrust setting.

2.2 Sampling line for smoke emissions

2.2.1 The sample shall be transferred from the probe to the sample collection system via a line of 4.0 to 8.5 mm inside diameter taking the shortest route practicable which shall in no case be greater than 25 m. The line temperature shall be maintained at a temperature between 60°C and 175°C with a stability of $\pm 15^\circ\text{C}$, except for the distance required to cool the gas from the engine exhaust temperature down to the line control temperature.

2.2.2 Sampling lines shall be as “straight through” as possible. Any necessary bends shall have radii which are greater than 10 times the inside diameter of the lines. The material of the lines shall be such as to discourage build-up of particulate matter or static electricity.

Note.— *Stainless steel or carbon-loaded grounded polytetrafluoroethylene (PTFE) meets these requirements.*

2.3 Smoke analysis system

Note.— *The method prescribed herein is based upon the measurement of the reduction in reflectance of a filter when stained by a given mass flow of exhaust sample.*

The arrangement of the various components of the system for acquiring the necessary stained filter samples shall be as shown schematically in Figure A2-1. An optional bypass around the volume meter may be installed to facilitate meter reading. The major elements of the system shall meet the following requirements:

- a) *sample size measurement:* a wet or dry positive displacement volume meter shall be used to measure sample volume to an accuracy of ± 2 per cent. The pressure and temperature at entry to this meter shall also be measured to accuracies of 0.2 per cent and $\pm 2^\circ\text{C}$ respectively;
- b) *sample flow rate measurement:* the sample flow rate shall be maintained at a value of 14 ± 0.5 L/min and the flowmeter for this purpose shall be able to make this measurement with an accuracy of ± 5 per cent;
- c) *filter and holder:* the filter holder shall be constructed in corrosion-resistant material and shall have the flow channel configuration shown in Figure A2-1. The filter material shall be Whatman type No. 4, or any equivalent approved by the certificating authority;
- d) *valves:* four valve elements shall be provided as indicated in Figure A2-1:
 - 1) valve A shall be a quick-acting, full-flow, flow diverter enabling the incoming sample to be directed through the measuring filter or around the bypass circuits or shut-off;

Note.— *Valve A may, if necessary, consist of two valves interlocked to give the requisite function.*

- 2) valves B and C shall be throttling valves used to establish the system flow rate;

- 3) valve D shall be a shut-off valve to enable the filter holder to be isolated;
all valves shall be made of corrosion-resistant material;
- e) *vacuum pump*: this pump shall have a no-flow vacuum capability of -75 kPa with respect to atmospheric pressure; its full-flow rate shall not be less than 26 L/min at standard temperature and pressure;
- f) *temperature control*: the analyser internal sample line through to the filter holder shall be maintained at a temperature between 60°C and 175°C with a stability of $\pm 15^{\circ}\text{C}$;

Note.— The objective is to prevent water condensation prior to reaching the filter holder and within it.

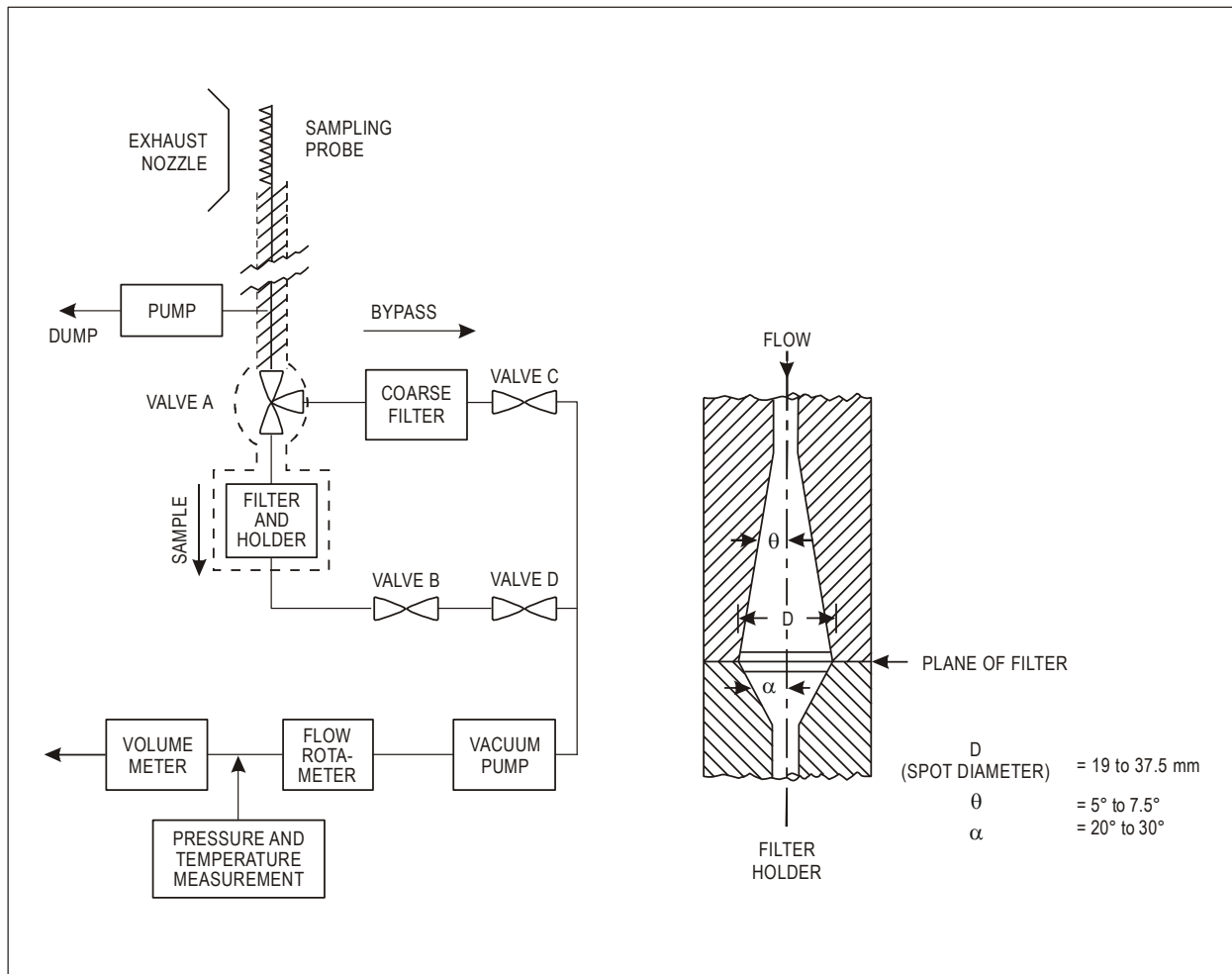

Figure A2-1. Smoke analysis system

- g) If it is desired to draw a higher sample flow rate through the probe than through the filter holder, an optional flow splitter may be located between the probe and valve A (Figure A2-1), to dump excess flow. The dump line shall be as close as possible to probe off-take and shall not affect the ability of the sampling system to maintain the required 80 per cent pressure drop across the probe assembly. The dump flow may also be sent to the CO₂ analyser or complete emissions analysis system.
- h) If a flow splitter is used, a test shall be conducted to demonstrate that the flow splitter does not change the smoke level passing to the filter holder. This may be accomplished by reversing the outlet lines from the flow splitter and showing that, within the accuracy of the method, the smoke level does not change.
- i) *leak performance*: the subsystem shall meet the requirements of the following test:
- 1) clamp clean filter material into holder;
 - 2) shut-off valve A, fully open valves B, C and D;
 - 3) run vacuum pump for one minute to reach equilibrium conditions;
 - 4) continue to pump and measure the flow rate through the meter over a period of five minutes. This flow rate shall not exceed 1 L/min (referred to standard temperature and pressure) and the system shall not be used until this standard has been achieved.
- j) *reflectometer*: the measurements of the diffuse reflection density of the filter material shall be by an instrument conforming to the International Organization for Standardization, Standard No. ISO 5-4¹. The diameter of the reflectometer light beam on the filter paper shall not exceed D/2 nor be less than D/10 where D is the diameter of filter stained spot as defined in Figure A2-1.

2.4 Fuel specifications

The fuel shall meet the specifications of Appendix 4.

2.5 Smoke measurement procedures

2.5.1 Engine operation

2.5.1.1 The engine shall be operated on a static test facility which is suitable and properly equipped for high accuracy performance testing.

2.5.1.2 The tests shall be made at the thrust settings approved by the certificating authority. The engine shall be stabilized at each setting.

1. International Organization for Standardization, Standard No. ISO 5-4: 1995 entitled *Photography – Density measurements – Part 4: Geometric conditions for reflection density*.

2.5.2 Leakage and cleanliness checks

No measurements shall be made until all sample transfer lines and valves are warmed up and stable. Prior to a series of tests the system shall be checked for leakage and cleanliness as follows:

- a) *leakage check*: isolate probe and close off end of sample line, perform leakage test as specified in 2.3 h) with the exceptions that valve A is opened and set to “bypass”, valve D is closed and that the leakage limit is 0.4 L/min at standard temperature and pressure. Restore probe and line interconnection;
- b) cleanliness check:
 - 1) open valves B, C and D
 - 2) run vacuum pump and alternately set valve A to “bypass” and “sample” to purge the entire system with clean air for five minutes;
 - 3) set valve A to “bypass”;
 - 4) close valve D and clamp clean filter material into holder. Open valve D;
 - 5) set valve A to “sample” and reset back to “bypass” after 50 kg of air per square metre of filter has passed through the filter material;
 - 6) measure resultant filter spot SN' as described in paragraph 3 of this appendix;
 - 7) if this SN' exceeds 3, the system shall be cleaned (or otherwise rectified) until a value lower than 3 is obtained.

The system shall not be used until the requirements of these leakage and cleanliness checks have been met.

2.5.3 Smoke measurement

Smoke measurement shall be made independently of other measurements unless the smoke values so measured are significantly below the limiting values, or unless it can be demonstrated that the smoke values from simultaneous smoke and gaseous emissions measurements are valid, in which case smoke measurements may be made simultaneously with gaseous emissions measurements. In all cases the bend radius requirements for sampling lines detailed in 2.2.2 shall be strictly observed. The smoke analysis subsystem shall be set up and conform to the specifications of 2.3. Referring to Figure A2-1, the following shall be the major operations in acquiring the stained filter specimens:

- a) during engine operation with the probe in position, valve A shall not be placed in the no-flow condition, otherwise particulate build-up in the lines might be encouraged;
- b) set valve A to “bypass”, close valve D and clamp clean filter into holder. Continue to draw exhaust sample in the bypass setting for at least five minutes while the engine is at or near to the required operating condition, valve C being set to give a flow rate of 14 ± 0.5 L/min;
- c) open valve D and set valve A to “sample”, use valve B to set flow rate again to value set in b);
- d) set valve A to “bypass” and close valve D, clamp clean filter material into the holder;
- e) when the engine is stabilized on condition, allow one minute of sample flow with settings as at d);

- f) open valve D, set valve A to “sample”, reset flow rate if necessary, and allow chosen sample volume (*see h*) to pass, before setting valve A back to “bypass” and close valve D;
- g) set aside stained filter for analysis, clamp clean filter into holder;
- h) the chosen sample sizes shall be such as to be within the range of 12 kg to 21 kg of exhaust gas per square metre of filter, and shall include samples which are either at the value of 16.2 kg of exhaust gas per square metre of filter or lie above and below that value. The number of samples at each engine operating condition shall not be less than 3 and e) to g) shall be repeated as necessary.

3. CALCULATION OF SMOKE NUMBER FROM MEASURED DATA

3.1 The stained filter specimens obtained as outlined in 2.5.3 shall be analysed using a reflectometer as specified in 2.3. The backing material used shall be black with an absolute reflectance of less than 3 per cent. The absolute reflectance reading R_S of each stained filter shall be used to calculate the reduction in reflectance by

$$SN' = 100(1 - R_S/R_W)$$

where R_W is the absolute reflectance of clean filter material.

3.2 The masses of the various samples shall be calculated by

$$W = 0.348 PV/T \times 10^{-2}(\text{kg})$$

where P and T are, respectively, the sample pressure in Pascal and the temperature in Kelvin, measured immediately upstream of the volume meter. V is the measured sample volume in cubic metres.

3.3 For each engine condition in the case that the sample sizes range above and below the reference value, the various values of SN' and W shall be plotted as SN' versus $\log W/A$, where A is the filter stain area (m^2). Using a least squares straight line fit, the value of SN' for $W/A = 16.2 \text{ kg/m}^2$ shall be estimated and reported as the Smoke Number (SN) for that engine mode. Where sampling at the sample reference size value only is employed, the reported SN shall be the arithmetic average of the various individual values of SN' .

4. REPORTING OF DATA TO THE CERTIFICATING AUTHORITY

The measured data shall be reported to the certificating authority. In addition the following data shall be reported for each test:

- a) sample temperature;
- b) sample pressure;
- c) actual sample volume at sampling conditions;
- d) actual sample flow rate at sampling conditions; and
- e) leak and cleanliness checks substantiation (*see 2.5.2*).

APPENDIX 3. INSTRUMENTATION AND MEASUREMENT TECHNIQUES FOR GASEOUS EMISSIONS

1. INTRODUCTION

Note.— *The procedures specified in this appendix are concerned with the acquisition of representative exhaust samples and their transmission to, and analysis by, the emissions measuring system. The procedures do not apply to engines employing afterburning. The methods proposed are representative of the best readily available and most established practice.*

Any equivalent procedures to those contained in this appendix shall only be allowed after prior application to and approval by the certifying authority.

2. DEFINITIONS

Where the following expressions are used in this appendix, they have the meanings ascribed to them below:

Accuracy. The closeness with which a measurement approaches the true value established independently.

Air/fuel ratio. The mass rate of airflow through the hot section of the engine divided by the mass rate of fuel flow to the engine.

Calibration gas. A high accuracy reference gas to be used for alignment, adjustment and periodic checks of instruments.

Gas concentration. The volume fraction of the component of interest in the gas mixture — expressed as volume percentage or as parts per million.

Flame ionization detector. A hydrogen-air diffusion flame detector that produces a signal nominally proportional to the mass-flow rate of hydrocarbons entering the flame per unit of time — generally assumed responsive to the number of carbon atoms entering the flame.

Interference. Instrument response due to presence of components other than the gas (or vapour) that is to be measured.

Noise. Random variation in instrument output not associated with characteristics of the sample to which the instrument is responding, and distinguishable from its drift characteristics.

Non-dispersive infrared analyser. An instrument that by absorption of infrared energy selectively measures specific components.

Parts per million (ppm). The unit volume gas concentration of a gas per million unit volume of the gas mixture of which it is a part.

Parts per million carbon (ppmC). The mole fraction of hydrocarbon multiplied by 10^6 measured on a methane-equivalence basis. Thus, 1 ppm of methane is indicated as 1 ppmC. To convert ppm concentration of any hydrocarbon to an equivalent ppmC value, multiply ppm gas concentration by the number of carbon atoms per molecule of the gas. For example, 1 ppm propane translates as 3 ppmC hydrocarbon; 1 ppm hexane as 6 ppmC hydrocarbon.

Reference gas. A mixture of gases of specified and known composition used as the basis for interpreting instrument response in terms of the gas concentration of the gas to which the instrument is responding.

Repeatability. The closeness with which a measurement upon a given invariant sample can be reproduced in short-term repetitions of the measurement with no intervening instrument adjustment.

Resolution. The smallest change in a measurement which can be detected.

Response. The change in instrument output signal that occurs with change in sample gas concentration.

Stability. The closeness with which repeated measurements upon a given invariant sample can be maintained over a given period of time.

Zero drift. Time-related deviation of instrument output from zero set point when it is operating on gas free of the component to be measured.

Zero gas. A gas to be used in establishing the zero, or no-response, adjustment of an instrument.

3. DATA REQUIRED

3.1 Gaseous emissions

Gas concentrations of the following emissions shall be determined:

- a) hydrocarbons (HC): a combined estimate of all hydrocarbon compounds present in the exhaust gas;
- b) carbon monoxide (CO);
- c) carbon dioxide (CO₂);

Note.— CO₂ is not a regulated engine emission but CO₂ concentration is required for calculation and check purposes.

- d) oxides of nitrogen (NO_x): an estimate of the sum of the two oxides, nitric oxide (NO) and nitrogen dioxide (NO₂); and
- e) nitric oxide (NO).

3.2 Other information

In order to normalize the emissions measurement data and to quantify the engine test characteristics, the following additional information shall be provided:

- a) inlet temperature;
- b) inlet humidity;
- c) atmospheric pressure;
- d) hydrogen/carbon ratio of fuel; and

- e) other required engine parameters (for example, thrust, rotor speeds, turbine temperatures and gas-generator air flow).

This data shall be obtained either by direct measurement or by calculation, as presented in Attachment F to this appendix.

4. GENERAL ARRANGEMENT OF THE SYSTEM

No desiccants, dryers, water traps or related equipment shall be used to treat the exhaust sample flowing to the oxides of nitrogen and the hydrocarbon analysis instrumentation. Requirements for the various component subsystems are given in 5, but the following list gives some qualifications and variations:

- a) It is assumed that each of the various individual subsystems includes the necessary flow control, conditioning and measurement facilities.
- b) The necessity for a dump and/or a hot-sample pump will depend on the ability to meet the sample transfer time and analysis subsystem sample flow rate requirements. This in turn depends on the exhaust sample driving pressure and line losses. It is considered that these pumps usually will be necessary at certain engine running conditions.
- c) The position of the hot pump, relative to the gas analysis subsystems, may be varied as required. (For example, some HC analysers contain hot pumps and so may be judged capable of being used upstream of the system hot pump.)

Note.— Figure A3-1 is a schematic drawing of the exhaust gas sampling and analytical system and typifies the basic requirements for emissions testing.

5. DESCRIPTION OF COMPONENT PARTS

Note.— A general description and specification of the principal elements in the engine exhaust emissions measurement system follows. Greater detail, where necessary, will be found in Attachments A, B and C to this appendix.

5.1 Sampling system

5.1.1 Sampling probe

The sampling probe shall meet the following requirements:

- a) The probe material with which the exhaust emission sample is in contact shall be stainless steel or any other non-reactive material.
- b) If a sampling probe with multiple sampling orifices is used:
 - 1) all sampling orifices shall be of equal diameter; and
 - 2) the sampling probe design shall be such that at least 80 per cent of the pressure drop through the probe assembly is taken at the orifices.
- c) The number of locations sampled shall not be less than 12.
- d) The sampling plane shall be as close to the engine exhaust nozzle exit plane as permitted by considerations of engine performance but in any case shall be within 0.5 nozzle diameter of the exit plane.
- e) The applicant shall provide evidence to the certificating authority, by means of detailed traverses, that the proposed probe design and position does provide a representative sample for each prescribed thrust setting.

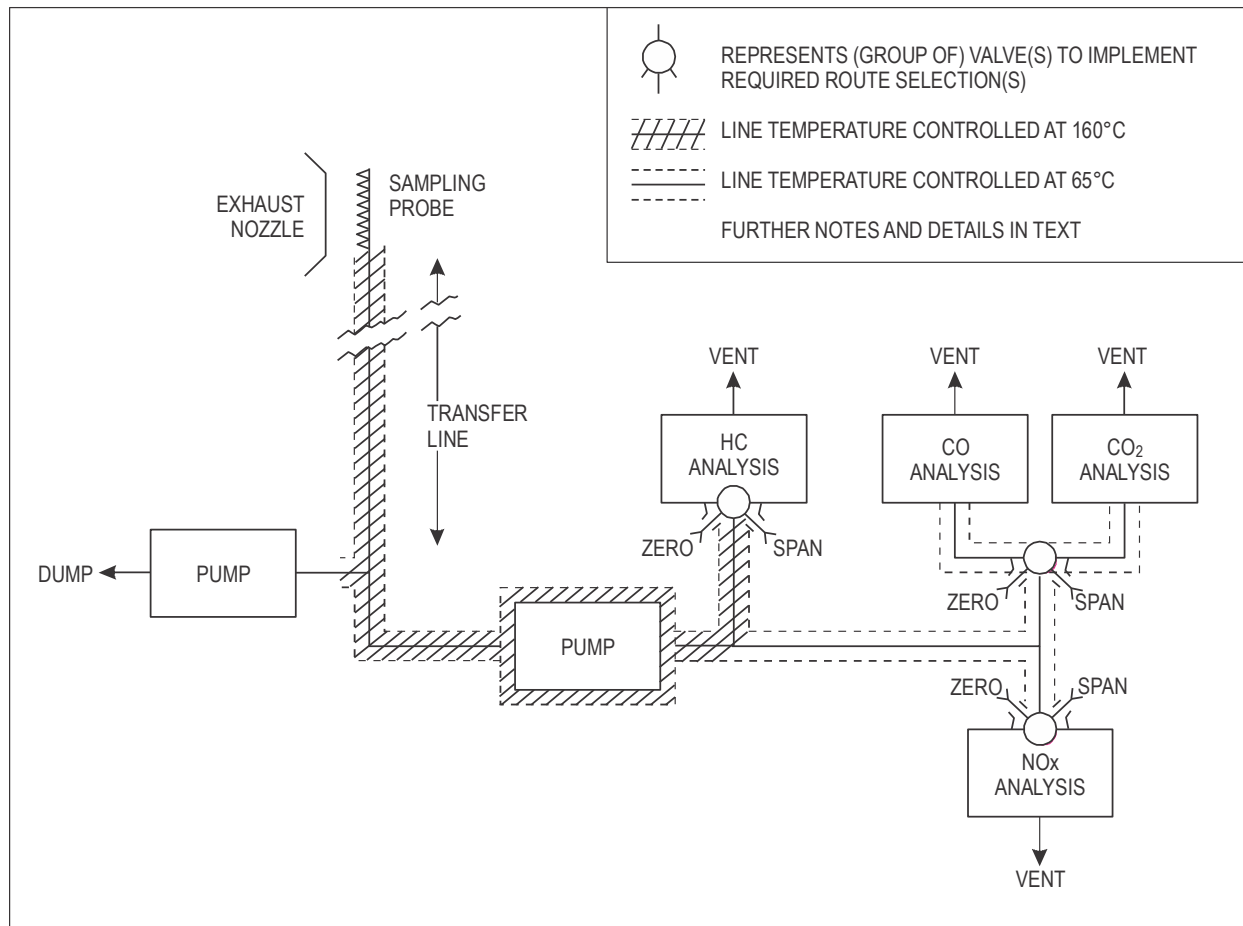

Figure A3-1. Sampling and analysis system, schematic

5.1.2 Sampling lines

The sample shall be transferred from the probe to the analysers via a line of 4.0 to 8.5 mm inside diameter, taking the shortest route practicable and using a flow rate such that the transport time is less than 10 seconds. The line shall be maintained at a temperature of $160^{\circ}\text{C} \pm 15^{\circ}\text{C}$, except for a) the distance required to cool the gas from the engine exhaust temperature down to the line control temperature, and b) the branch which supplies samples to the CO, CO₂, and NO_x analysers. This branch line shall be maintained at a temperature of $65^{\circ}\text{C} \pm 15^{\circ}\text{C}$. When sampling to measure HC, CO, CO₂ and NO_x components the line shall be constructed in stainless steel or carbon-loaded grounded PTFE.

5.2 HC analyser

The measurement of total hydrocarbon sample content shall be made by an analyser using the heated flame ionization detector (FID), between the electrodes of which passes an ionization current proportional to the mass rate of hydrocarbon entering a hydrogen flame. The analyser shall be deemed to include components arranged to control temperature and flow rates of sample, sample bypass, fuel and diluent gases, and to enable effective span and zero calibration checks.

Note.— An overall specification is given in Attachment A to this appendix.

5.3 CO and CO₂ analysers

Non-dispersive infrared analysers shall be used for the measurements of these components, and shall be of the design which utilizes differential energy absorption in parallel reference and sample gas cells, the cell or group of cells for each of these gas constituents being sensitized appropriately. This analysis subsystem shall include all necessary functions for the control and handling of sample, zero and span gas flows. Temperature control shall be that appropriate to whichever basis of measurement, wet or dry, is chosen.

Note.— An overall specification is given in Attachment B to this appendix.

5.4 NO_x analyser

The measurement of NO gas concentration shall be by the chemiluminescent method in which the measure of the radiation intensity emitted during the reaction of the NO in the sample with added O₃ is the measure of the NO gas concentration. The NO₂ component shall be converted to NO in a converter of the requisite efficiency prior to measurement. The resultant NO_x measurement system shall include all necessary flow, temperature and other controls and provide for routine zero and span calibration as well as for converter efficiency checks.

Note.— An overall specification is given in Attachment C to this appendix.

6. GENERAL TEST PROCEDURES

6.1 Engine operation

6.1.1 The engine shall be operated on a static test facility which is suitable and properly equipped for high accuracy performance testing.

6.1.2 The emissions tests shall be made at the thrust settings prescribed by the certificating authority. The engine shall be stabilized at each setting.

6.2 Major instrument calibration

Note.— The general objective of this calibration is to confirm stability and linearity.

6.2.1 The applicant shall satisfy the certificating authority that the calibration of the analytical system is valid at the time of the test.

6.2.2 For the hydrocarbon analyser this calibration shall include checks that the detector oxygen and differential hydrocarbon responses are within the limits specified in Attachment A to this appendix. The efficiency of the NO₂/NO converter shall also be checked and verified to meet the requirements in Attachment C to this appendix.

6.2.3 The procedure for checking the performance of each analyser shall be as follows (using the calibration and test gases as specified in Attachment D to this appendix):

- a) introduce zero gas and adjust instrument zero, recording setting as appropriate;
- b) for each range to be used operationally, introduce calibration gas of (nominally) 90 per cent range full-scale deflection (FSD) gas concentration; adjust instrument gain accordingly and record its setting;

- c) introduce approximately 30 per cent, 60 per cent, and 90 per cent range FSD gas concentration and record analyser readings;
- d) fit a least squares straight line to the zero, 30 per cent, 60 per cent and 90 per cent gas concentration points. For the CO and/or CO₂ analyser used in their basic form without linearization of output, a least squares curve of appropriate mathematical formulation shall be fitted using additional calibration points if judged necessary. If any point deviates by more than 2 per cent of the full scale value (or ± 1 ppm*, whichever is greater) then a calibration curve shall be prepared for operational use.

6.3 Operation

6.3.1 No measurements shall be made until all instruments and sample transfer lines are warmed up and stable and the following checks have been carried out:

- a) leakage check: prior to a series of tests, the system shall be checked for leakage by isolating the probe and the analysers, connecting and operating a vacuum pump to verify that the system leakage flow rate is less than 0.4 L/min referred to standard temperature and pressure. The vacuum pump shall have a no-flow vacuum capability of -75 kPa with respect to atmospheric pressure; its full-flow rate shall not be less than 26 L/min at standard temperature and pressure;
- b) cleanliness check: isolate the gas sampling system from the probe and connect the end of the sampling line to a source of zero gas. Warm the system up to the operational temperature needed to perform hydrocarbon measurements. Operate the sample flow pump and set the flow rate to that used during engine emission testing. Record the hydrocarbon analyser reading. The reading shall not exceed 1 per cent of the engine idle emission level or 1 ppm (both expressed as methane), whichever is the greater.

Note 1.— It is good practice to back-purge the sampling lines during engine running, while the probe is in the engine exhaust but emissions are not being measured, to ensure that no significant contamination occurs.

Note 2.— It is also good practice to monitor the inlet air quality at the start and end of testing and at least once per hour during a test. If levels are considered significant, then they should be taken into account.

6.3.2 The following procedure shall be adopted for operational measurements:

- a) apply appropriate zero gas and make any necessary instrument adjustments;
- b) apply appropriate calibration gas at a nominal 90 per cent FSD gas concentration for the ranges to be used, adjust and record gain settings accordingly;
- c) when the engine has been stabilized at the required thrust setting, continue to run it and observe pollutant gas concentrations until a stabilized reading is obtained, which shall be recorded;
- d) recheck zero and calibration points at the end of the test and also at intervals not greater than 1 hour during tests. If either has changed by more than ± 2 per cent of range FSD, the test shall be repeated after restoration of the instrument to within its specification.

6.4 Carbon balance check

Each test shall include a check that the air/fuel ratio as estimated from the integrated sample total carbon gas concentration exclusive of smoke, agrees with the estimate based on engine air/fuel ratio with an accuracy of ± 15 per cent for the taxi/ground idle mode, and with an accuracy of ± 10 per cent for all other modes (*see* 7.1.2).

* Except for the CO₂ analyser, for which the value shall be ± 100 ppm.

7. CALCULATIONS

7.1 Gaseous emissions

7.1.1 General

The analytical measurements made shall be the gas concentrations of the various gaseous emissions, as detected at their respective analysers for a range of combustor inlet temperatures (T_B) encompassing the four LTO operating modes. Using the calculations of 7.1.2, or the alternative methods defined in Attachment E to this appendix, the measured emissions indices (EI) for each gaseous emission shall be established. To account for deviations from reference atmospheric conditions, the corrections of 7.1.3 shall be applied. Note that these corrections may also be used to account for deviations of the tested engine from the reference standard engine where appropriate (*see* Appendix 6, paragraph 1 f). Using combustor inlet temperature (T_B) as a correlating parameter, the emissions indices and fuel flow corresponding to the operation at the four LTO operating modes of a reference standard engine under reference day conditions shall then be established using the procedures of 7.2.

7.1.2 Basic parameters

$$EI_p(\text{emission index for component } p) = \frac{\text{mass of } p \text{ produced in g}}{\text{mass of fuel used in kg}}$$

$$EI(\text{CO}) = \left(\frac{[\text{CO}]}{[\text{CO}_2] + [\text{CO}] + [\text{HC}]} \right) \left(\frac{10^3 M_{\text{CO}}}{M_C + (n/m)M_H} \right) \left(1 + [\text{CO}_2] (P_0/m) \right)$$

$$EI(\text{HC}) = \left(\frac{[\text{HC}]}{[\text{CO}_2] + [\text{CO}] + [\text{HC}]} \right) \left(\frac{10^3 M_{\text{HC}}}{M_C + (n/m)M_H} \right) \left(1 + [\text{CO}_2] (P_0/m) \right)$$

$$EI(\text{NO}_x) \text{ as } \text{NO}_2 = \left(\frac{[\text{NO}_x]}{[\text{CO}_2] + [\text{CO}] + [\text{HC}]} \right) \left(\frac{10^3 M_{\text{NO}_2}}{M_C + (n/m)M_H} \right) \left(1 + [\text{CO}_2] (P_0/m) \right)$$

$$\frac{\text{Air}}{\text{Fuel}} \text{ Ratio} = P_0/m \left(\frac{M_{\text{AIR}}}{M_C + (n/m)M_H} \right)$$

where

$$P_0/m = \frac{2Z - n/m}{4(1 + h_{\text{vol}} - [TZ/2])}$$

and

$$Z = \frac{2 - [\text{CO}] - ([2/x] - [y/2x]) [\text{HC}] + [\text{NO}_2]}{[\text{CO}_2] + [\text{CO}] + [\text{HC}]}$$

M_{AIR} molecular mass of dry air = 28.966 g or, where appropriate, = (32 $[\text{O}_2]_b$ + 28.156 4 $[\text{N}_2]_b$ + 44.011 $[\text{CO}_2]_b$) g

M_{CO} molecular mass of CO = 28.011 g

M_{HC} molecular mass of exhaust hydrocarbons, taken as CH_4 = 16.043 g

M_{NO_2}	molecular mass of $\text{NO}_2 = 46.008 \text{ g}$
M_{C}	atomic mass of carbon = 12.011 g
M_{H}	atomic mass of hydrogen = 1.008 g
$[\text{O}_2]_{\text{b}}$	gas concentration of O_2 in dry air, by volume = 0.209 5
$[\text{N}_2]_{\text{b}}$	gas concentration of $\text{N}_2 + \text{rare gases}$ in dry air, by volume = 0.790 2
$[\text{CO}_2]_{\text{b}}$	gas concentration of CO_2 in dry air, by volume = 0.000 3
$[\text{HC}]$	mean gas concentration of exhaust hydrocarbons vol/vol, wet, expressed as carbon
$[\text{CO}]$	mean gas concentration of CO in exhaust sample vol/vol, wet
$[\text{CO}_2]$	mean gas concentration of CO_2 in exhaust sample vol/vol, wet
$[\text{NOx}]$	mean gas concentration of NO and NO_2 in exhaust sample vol/vol, wet = $[\text{NO} + \text{NO}_2]$
$[\text{NO}]$	mean gas concentration of NO in exhaust sample, vol/vol, wet
$[\text{NO}_2]$	mean gas concentration of NO_2 in exhaust sample, vol/vol, wet
	$= \frac{([\text{NOx}]_c - [\text{NO}])}{\eta}$
$[\text{NOx}]_c$	mean gas concentration of NO in exhaust sample after passing through the NO_2/NO converter, vol/vol, wet
η	efficiency of NO_2/NO converter
h_{vol}	humidity of ambient air, vol water/vol dry air
m	number of C atoms in characteristic fuel molecule
n	number of H atoms in characteristic fuel molecule
x	number of C atoms in characteristic exhaust hydrocarbon molecule
y	number of H atoms in characteristic exhaust hydrocarbon molecule

The value of n/m , the ratio of the atomic hydrogen to atomic carbon of the fuel used, is evaluated by fuel type analysis. The ambient air humidity, h_{vol} , shall be measured at each set condition. In the absence of contrary evidence as to the characterization (x, y) of the exhaust hydrocarbons, the values $x = 1, y = 4$ are to be used. If dry or semi-dry CO and CO_2 measurements are to be used then these shall first be converted to the equivalent wet gas concentration as shown in Attachment E to this appendix, which also contains interference correction formulas for use as required.

7.1.3 Correction of emission indices to reference conditions

7.1.3.1 Corrections shall be made to the measured engine emission indices for all pollutants in all relevant engine modes to account for deviations from the reference atmospheric conditions (ISA at sea level) of the actual test inlet air conditions of

temperature and pressure. These corrections may also be used to account for deviations of the tested engine from the reference standard engine where appropriate (*see* Appendix 6, 1 f). The reference value for humidity shall be 0.00634 kg water/kg dry air. Thus, EI corrected = $K \times$ EI measured, where the generalized expression for K is:

$$K = (P_{Bref}/P_B)^a \times (FAR_{ref}/FAR_B)^b \times \exp((T_{Bref} - T_B)/c) \times \exp(d[h_{mass} - 0.00634])$$

P_B	Combustor inlet pressure, measured
T_B	Combustor inlet temperature, measured
FAR_B	Fuel/air ratio in the combustor
h_{mass}	Ambient air humidity, kg water/kg dry air
P_{ref}	ISA sea level pressure
T_{ref}	ISA sea level temperature
P_{Bref}	Pressure at the combustor inlet of the engine tested (or the reference engine if the data is corrected to a reference engine) associated with T_B under ISA sea level conditions.
T_{Bref}	Temperature at the combustor inlet under ISA sea level conditions for the engine tested (or the reference engine if the data is to be corrected to a reference engine). This temperature is the temperature associated with each thrust level specified for each mode.
FAR_{ref}	Fuel/air ratio in the combustor under ISA sea level conditions for the engine tested (or the reference engine if the data is to be corrected to a reference engine).
a, b, c, d	Specific constants which may vary for each pollutant and each engine type.

The combustor inlet parameters shall preferably be measured but may be calculated from ambient conditions by appropriate formulas.

7.1.3.2 Using the recommended curve fitting technique of 7.2 to relate emission indices to combustor inlet temperature effectively eliminates the $\exp((T_{Bref} - T_B)/c)$ term from the generalized equation and for most cases the (FAR_{ref}/FAR_B) term may be considered unity. For the emissions indices of CO and HC many testing facilities have determined that the humidity term is sufficiently close to unity to be eliminated from the expression and that the exponent of the (P_{Bref}/P_B) term is close to unity. Thus,

$$\text{EI(CO) corrected} = \text{EI derived from } (P_B/P_{Bref}) \times \text{EI(CO) v. } T_B \text{ curve}$$

$$\text{EI(HC) corrected} = \text{EI derived from } (P_B/P_{Bref}) \times \text{EI(HC) v. } T_B \text{ curve}$$

$$\text{EI(NOx) corrected} = \text{EI derived from } \text{EI(NOx)} \times (P_{Bref}/P_B)^{0.5} \times \exp(19 [h_{mass} - 0.00634]) \text{ v. } T_B \text{ curve}$$

If this recommended method for the CO and HC emissions index correction does not provide a satisfactory correlation, an alternative method using parameters derived from component tests may be used.

Any other methods used for making corrections to CO, HC and NOx emissions indices shall have the approval of the certifying authority.

7.2 Control parameter functions

(D_p, F_{oo}, π)

7.2.1 Definitions

D_p	The mass of any gaseous pollutant emitted during the reference emissions landing and take-off cycle.
F_{oo}	Rated thrust (<i>see</i> Part I, Chapter 1, Definitions)
F_n	Thrust at LTO operating mode n (kN)
W_f	Fuel mass flow rate of the reference standard engine under ISA sea level conditions (kg/s)
W_{f_n}	Fuel mass flow rate of the reference standard engine under ISA sea level conditions at LTO operating mode n
π	The ratio of the mean total pressure at the last compressor discharge plane of the compressor to the mean total pressure at the compressor entry plane when the engine is developing take-off thrust rating at ISA sea level static conditions

7.2.2 The emissions indices (EI_n) for each pollutant, corrected to reference atmospheric conditions and, if necessary, to the reference standard engine, (EI_n (corrected)), shall be obtained for each LTO operating mode. A minimum of three test points shall be required to define the idle mode. The following relationships shall be determined under reference atmospheric conditions for each gaseous emission:

- between EI (corrected) and T_B ;
- between W_f and T_B ; and
- between F and T_B .

Note 1.— These relationships are illustrated, for example, by Figure A3-2 a), b) and c).

Note 2.— The relationships b) and c) may be established directly from engine test data, or may be derived from a validated engine performance model.

7.2.2.1 A reference engine is defined as an engine substantially configured to the production standard of the engine type and with fully representative operating and performance characteristics.

7.2.2.2 The manufacturer shall also supply to the certificating authority all of the necessary engine performance data to substantiate these relationships and for ISA sea level ambient conditions:

- rated thrust (F_{oo}); and
- engine pressure ratio (π) at maximum rated thrust.

Note.— These are illustrated by Figure A3-2 d).

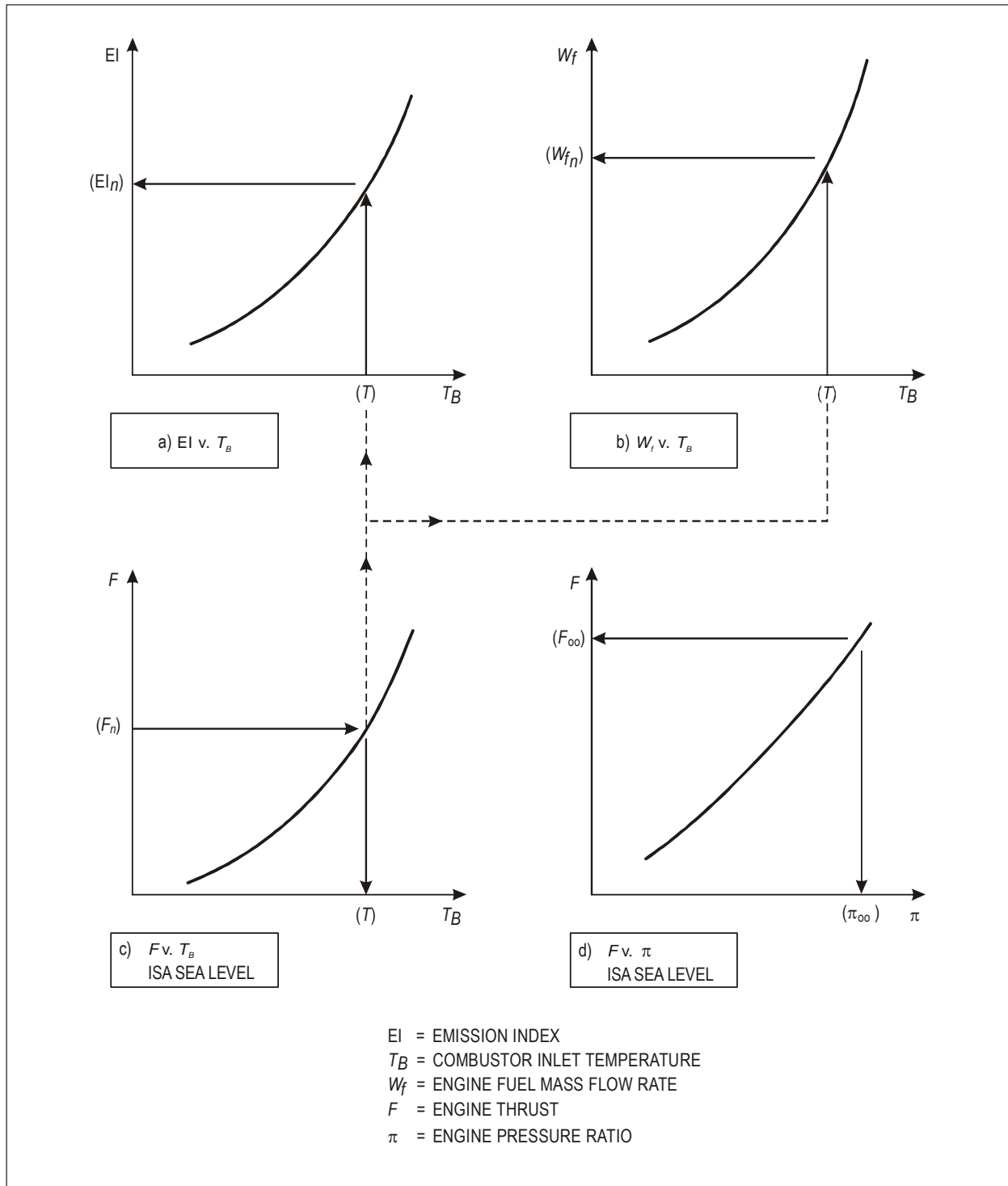

Figure A3-2. Calculation procedure

7.2.3 The estimation of EI (corrected) for each gaseous emission at the four LTO operating modes shall comply with the following general procedure:

- a) determine the combustor inlet temperature (T_B) (Figure A3-2 c)) at the values of F_n corresponding to the four LTO operating modes, n , under reference atmospheric conditions;
- b) from the EI (corrected)/ T_B characteristic (Figure A3-2 a)), determine the EI_n value corresponding to T_B ;
- c) from the W_f/T_B characteristic (Figure A3-2 b)), determine the W_{f_n} value corresponding to T_B ;
- d) note the ISA maximum rated thrust and pressure ratio values. These are F_{oo} and π respectively (Figure A3-2 d));
- e) calculate, for each pollutant $D_p = \Sigma (EI_n) (W_{f_n}) (t)$ where:

t is the time in LTO mode (minutes);

W_{f_n} is the fuel mass flow rate (kg/min); and

Σ is the summation for the set of modes comprising the reference LTO cycle.

7.2.4 While the methodology described above is the recommended method, the certifying authority may accept equivalent mathematical procedures which utilize mathematical expressions representing the curves illustrated if the expression have been derived using an accepted curve fitting technique.

7.3 Exceptions to the proposed procedures

In those cases where the configuration of the engine or other extenuating conditions exist which would prohibit the use of this procedure, the certifying authority, after receiving satisfactory technical evidence of equivalent results obtained by an alternative procedure, may approve an alternative procedure.

ATTACHMENT A TO APPENDIX 3. SPECIFICATION FOR HC ANALYSER

Note 1.— As outlined in 5.2 of Appendix 3, the measuring element in this analyser is the flame ionization detector (FID) in which the whole or a representative portion of the sample flow is admitted into a hydrogen-fuelled flame. With suitably positioned electrodes an ionization current can be established which is a function of the mass rate of hydrocarbon entering the flame. It is this current which, referred to an appropriate zero, is amplified and ranged to provide the output response as a measure of the hydrocarbon gas concentration expressed as ppmC equivalent.

Note 2.— See Attachment D for information on calibration and test gases.

1. GENERAL

Precautions: The performance specifications indicated are generally for analyser full scale. Errors at part scale may be a significantly greater percentage of reading. The relevance and importance of such increases shall be considered when preparing to make measurements. If better performance is necessary, then appropriate precautions shall be taken.

The instrument to be used shall be such as to maintain the temperature of the detector and sample-handling components at a set point not less than 150°C. The leading specification points shall be as follows, the detector response having been optimized and the instrument generally having stabilized:

- a) *Total range:* 0 to 5 000 ppmC in appropriate ranges.
- b) *Resolution:* better than 0.5 per cent of full scale of range used or 0.5 ppmC, whichever is greater.
- c) *Repeatability:* better than ± 1 per cent of full scale of range used, or ± 0.5 ppmC, whichever is greater.
- d) *Stability:* better than ± 2 per cent of full scale of range used or ± 1.0 ppmC, whichever is greater, in a period of 1 hour.
- e) *Zero drift:* less than ± 1 per cent of full scale of range used or ± 0.5 ppmC, whichever is greater, in a period of 1 hour.
- f) *Noise:* 0.5 Hz and greater, less than ± 1 per cent of full scale of range used or ± 0.5 ppmC, whichever is greater.
- g) *Response time:* shall not exceed 10 seconds from inlet of the sample to the analysis system, to the achievement of 90 per cent of the final reading.
- h) *Linearity:* response with propane in air shall be linear for each range within ± 2 per cent of full scale, otherwise calibration corrections shall be used.

2. SYNERGISTIC EFFECTS

Note.— In application there are two aspects of performance which can affect the accuracy of measurement:

- a) *the oxygen effect (whereby differing proportions of oxygen present in the sample give differing indicated hydrocarbon gas concentration for constant actual HC gas concentrations); and*

- b) the relative hydrocarbon response (whereby there is a different response to the same sample hydrocarbon gas concentrations expressed as equivalent ppmC, dependent on the class or admixture of classes of hydrocarbon compounds).

The magnitude of the effects noted above shall be determined as follows and limited accordingly:

Oxygen response: measure the response with two blends of propane, at approximately 500 ppmC gas concentration known to a relative accuracy of ± 1 per cent, as follows:

- a) propane in 10 ± 1 per cent O_2 , balance N_2 ; and
- b) propane in 21 ± 1 per cent O_2 , balance N_2 .

If R_1 and R_2 are the respective normalized responses then $(R_1 - R_2)$ shall be less than 3 per cent of R_1 .

Differential hydrocarbon response: measure the response with four blends of different hydrocarbons in air, at gas concentrations of approximately 500 ppmC, known to a relative accuracy of ± 1 per cent, as follows:

- a) propane in zero air;
- b) propylene in zero air;
- c) toluene in zero air; and
- d) n-hexane in zero air.

If R_a , R_b , R_c and R_d are, respectively, the normalized responses (with respect to propane), then $(R_a - R_b)$, $(R_a - R_c)$ and $(R_a - R_d)$ shall each be less than 5 per cent of R_a .

3. OPTIMIZATION OF DETECTOR RESPONSE AND ALIGNMENT

3.1 The manufacturer's instructions for initial setting up procedures and ancillary services and supplies required shall be implemented, and the instrument allowed to stabilize. All setting adjustments shall involve iterative zero checking, and correction as necessary. Using as sample a mixture of approximately 500 ppmC of propane in air, the response characteristics for variations first in fuel flow and then, near an optimum fuel flow, for variations in dilution air flow to select its optimum shall be determined. The oxygen and differential hydrocarbon responses shall then be determined as indicated above.

3.2 The linearity of each analyser range shall be checked by applying propane in air samples at gas concentrations of approximately 30, 60 and 90 per cent of full scale. The maximum response deviation of any of these points from a least squares straight line (fitted to the points and zero) shall not exceed ± 2 per cent of full scale value. If it does, a calibration curve shall be prepared for operational use.

ATTACHMENT B TO APPENDIX 3. SPECIFICATION FOR CO AND CO₂ ANALYSERS

Note 1.— Paragraph 5.3 of Appendix 3 summarizes the characteristics of the analysis subsystem to be employed for the individual measurements of CO and CO₂ gas concentrations in the exhaust gas sample. The instruments are based on the principle of non-dispersive absorption of infrared radiation in parallel reference and sample gas cells. The required ranges of sensitivity are obtained by use of stacked sample cells or changes in electronic circuitry or both. Interferences from gases with overlapping absorption bands may be minimized by gas absorption filters and/or optical filters, preferably the latter.

Note 2.— See Attachment D for information on calibration and test gases.

Precautions: The performance specifications indicated are generally for analyser full scale. Errors at part scale may be a significantly greater percentage of reading. The relevance and importance of such increases shall be considered when preparing to make measurements. If better performance is necessary, then appropriate precautions shall be taken.

The principal performance specification shall be as follows:

CO analyser

- a) *Total range:* 0 to 2 500 ppm in appropriate ranges.
- b) *Resolution:* better than 0.5 per cent of full scale of range used or 1 ppm, whichever is greater.
- c) *Repeatability:* better than ± 1 per cent of full scale of range used, or ± 2 ppm, whichever is greater.
- d) *Stability:* better than ± 2 per cent of full scale of range used or ± 2 ppm, whichever is greater, in a period of 1 hour.
- e) *Zero drift:* less than ± 1 per cent of full scale of range used or ± 2 ppm, whichever is greater, in a period of 1 hour.
- f) *Noise:* 0.5 Hz and greater, less than ± 1 per cent of full scale of range used or ± 1 ppm, whichever is greater.
- g) *Interferences:* to be limited with respect to indicated CO gas concentration as follows:
 - 1) less than 500 ppm/per cent ethylene gas concentration
 - 2) less than 2 ppm/per cent CO₂ gas concentration
 - 3) less than 2 ppm/per cent water vapour.*

If the interference limitation(s) for CO₂ and/or water vapour cannot be met, appropriate correction factors shall be determined, reported and applied.

Note.— It is recommended, as consistent with good practice, that such correction procedures be adopted in all cases.

* Need not apply where measurements are on a “dry” basis.

CO₂ analyser

- a) *Total range*: 0 to 10 per cent in appropriate ranges.
- b) *Resolution*: better than 0.5 per cent of full scale of range used or 100 ppm, whichever is greater.
- c) *Repeatability*: better than ± 1 per cent of full scale of range used or ± 100 ppm, whichever is greater.
- d) *Stability*: better than ± 2 per cent of full scale of range used or ± 100 ppm, whichever is greater, in a period of 1 hour.
- e) *Zero drift*: less than ± 1 per cent of full scale of range used or ± 100 ppm, whichever is greater, in a period of 1 hour.
- f) *Noise*: 0.5 Hz and greater, less than ± 1 per cent of full scale of range used or ± 100 ppm, whichever is greater.
- g) The effect of oxygen (O₂) on the CO₂ analyser response shall be checked. For a change from 0 per cent O₂ to 21 per cent O₂, the response of a given CO₂ gas concentration shall not change by more than 2 per cent of reading. If this limit cannot be met an appropriate correction factor shall be applied.

Note.— *It is recommended, as consistent with good practice, that such correction procedures be adopted in all cases.*

CO and CO₂ analysers

- a) *Response time*: shall not exceed 10 seconds from inlet of the sample to the analysis system to the achievement of 90 per cent of the final reading.
- b) *Sample temperature*: the normal mode of operation is for analysis of the sample in its (untreated) “wet” condition. This requires that the sample cell and all other components in contact with the sample in this subsystem be maintained at a temperature of not less than 50°C, with a stability of $\pm 2^\circ\text{C}$. The option to measure CO and CO₂ on a dry basis (with suitable water traps) is allowed, in which case unheated analysers are permissible and the interference limits for H₂O vapour removed, and subsequent correction for inlet water vapour and water of combustion is required.
- c) *Calibration curves*:
 - 1) Analysers with a linear signal output characteristic shall be checked on all working ranges using calibration gases at known gas concentrations of approximately 0, 30, 60 and 90 per cent of full scale. The maximum response deviation of any of these points from a least squares straight line, fitted to the points and the zero reading, shall not exceed ± 2 per cent of the full scale value. If it does then a calibration curve shall be prepared for operational use.
 - 2) Analysers with a non-linear signal output characteristic, and those that do not meet the requirements of linearity given above, shall have calibration curves prepared for all working ranges using calibration gases at known gas concentrations of approximately 0, 30, 60 and 90 per cent of full scale. Additional mixes shall be used, if necessary, to define the curve shape properly.

ATTACHMENT C TO APPENDIX 3. SPECIFICATION FOR NO_x ANALYSER

Note.— See Attachment D for information on calibration and test gases.

1. As indicated in 5.4 of Appendix 3, the measurement of the oxides of nitrogen gas concentration shall be by the chemiluminescent technique in which radiation emitted by the reaction of NO and O₃ is measured. This method is not sensitive to NO₂ and therefore the sample shall be passed through a converter in which NO₂ is converted to NO before the measurement of total NO_x is made. Both the original NO and the total NO_x gas concentrations shall be recorded. Thus by difference, a measure of the NO₂ gas concentration shall be obtained.

2. The instrument to be used shall be complete with all necessary flow control components, such as regulators, valves, flowmeters, etc. Materials in contact with the sample gas shall be restricted to those which are resistant to attack by oxides of nitrogen, such as stainless steel, glass, etc. The temperature of the sample shall everywhere be maintained at values, consistent with the local pressures, which avoid condensation of water.

Precautions: The performance specifications indicated are generally for analyser full scale. Errors at part scale may be a significantly greater percentage of reading. The relevance and importance of such increases shall be considered when preparing to make measurements. If better performance is necessary, then appropriate precautions shall be taken.

3. The principal performance specification, determined for the instrument operated in an ambient temperature stable to within 2°C, shall be as follows:

- a) *Total range:* 0 to 2 500 ppm in appropriate ranges.
- b) *Resolution:* better than 0.5 per cent of full scale of range used or 1 ppm, whichever is greater.
- c) *Repeatability:* better than ±1 per cent of full scale of range used, or ±1 ppm, whichever is greater.
- d) *Stability:* better than ±2 per cent of full scale of range used or ±1 ppm, whichever is greater, in a period of 1 hour.
- e) *Zero drift:* less than ±1 per cent of full scale of range used or ±1 ppm, whichever is greater, in a period of 1 hour.
- f) *Noise:* 0.5 Hz and greater, less than ±1 per cent of full scale of range used or ±1 ppm, whichever is greater, in a period of 2 hours.
- g) *Interference:* suppression for samples containing CO₂ and water vapour, shall be limited as follows:
 - 1) less than 0.05 per cent reading/per cent CO₂ gas concentration;
 - 2) less than 0.1 per cent reading/per cent water vapour gas concentration.

If the interference limitation(s) for CO₂ and/or water vapour cannot be met, appropriate correction factors shall be determined, reported and applied.

Note.— It is recommended, as consistent with good practice, that such correction procedures be adopted in all cases.

- h) *Response time*: shall not exceed 10 seconds from inlet of the sample to the analysis system to the achievement of 90 per cent of the final reading.
- i) *Linearity*: better than ± 2 per cent of full scale of range used or ± 2 ppm, whichever is greater.
- j) *Converter*: shall be designed and operated in such a manner as to reduce NO_2 present in the sample to NO . The converter shall not affect the NO originally in the sample.

The converter efficiency shall not be less than 90 per cent. This efficiency value shall be used to correct the measured sample NO_2 value (i.e. $[\text{NO}_x]_c - [\text{NO}]$) to that which would have been obtained if the efficiency had not been 100 per cent.

ATTACHMENT D TO APPENDIX 3. CALIBRATION AND TEST GASES

Table of calibration gases

<i>Analyser</i>	<i>Gas</i>	<i>Accuracy*</i>
HC	propane in zero air	±2 per cent or ±0.05 ppm**
CO ₂	CO ₂ in zero air	±2 per cent or ±100 ppm**
CO	CO in zero air	±2 per cent or ±2 ppm**
NOx	NOx in zero nitrogen	±2 per cent or ±1 ppm**

* Taken over the 95 per cent confidence interval.

** Whichever is greater.

The above gases are required to carry out the routine calibration of analysers during normal operational use.

Table of test gases

<i>Analyser</i>	<i>Gas</i>	<i>Accuracy*</i>
HC	propane in 10 ±1 per cent O ₂ balance zero nitrogen	±1 per cent
HC	propane in 21 ±1 per cent O ₂ balance zero nitrogen	±1 per cent
HC	propylene in zero air	±1 per cent
HC	toluene in zero air	±1 per cent
HC	n-hexane in zero air	±1 per cent
HC	propane in zero air	±1 per cent
CO ₂	CO ₂ in zero air	±1 per cent
CO ₂	CO ₂ in zero nitrogen	±1 per cent
CO	CO in zero air	±1 per cent
NOx	NO in zero nitrogen	±1 per cent

* Taken over the 95 per cent confidence interval.

The above gases are required to carry out the tests of Attachments A, B and C.

Carbon monoxide and carbon dioxide calibration gases may be blended singly or as dual component mixtures. Three component mixtures of carbon monoxide, carbon dioxide and propane in zero air may be used, provided the stability of the mixture is assured.

Zero gas as specified for the CO, CO₂ and HC analysers shall be zero air (which includes “artificial” air with 20 to 22 per cent O₂ blended with N₂). For the NO_x analyser, zero nitrogen shall be used as the zero gas. Impurities in both kinds of zero gas shall be restricted to be less than the following gas concentrations:

- 1 ppm C
- 1 ppm CO
- 100 ppm CO₂
- 1 ppm NO_x

The applicant shall ensure that commercial gases, as supplied, do in fact meet this specification, or are so specified by the vendor.

**ATTACHMENT E TO APPENDIX 3. THE CALCULATION OF THE EMISSIONS
PARAMETERS — BASIS, MEASUREMENT CORRECTIONS
AND ALTERNATIVE NUMERICAL METHOD**

1. SYMBOLS

AFR	air/fuel ratio, the ratio of the mass flow rate of dry air to that of the fuel
EI	emission index; $10^3 \times$ mass flow rate of gaseous emission product in exhaust per unit mass flow rate of fuel
K	ratio of gas concentration measured wet to that measured dry (after cold trap)
L, L'	analyser interference coefficient for interference by CO ₂
M, M'	analyser interference coefficient for interference by H ₂ O
M _{AIR}	molecular mass of dry air = 28.966 g or, where appropriate, = (32 R + 28.156 4 S + 44.011 T)g
M _{CO}	molecular mass of CO = 28.011 g
M _{HC}	molecular mass of exhaust hydrocarbon, taken as CH ₄ = 16.043 g
M _{NO₂}	molecular mass of NO ₂ = 46.008 g
M _C	atomic mass of carbon = 12.011 g
M _H	atomic mass of hydrogen = 1.008 g
P ₁	number of moles of CO ₂ in the exhaust sample per mole of fuel
P ₂	number of moles of N ₂ in the exhaust sample per mole of fuel
P ₃	number of moles of O ₂ in the exhaust sample per mole of fuel
P ₄	number of moles of H ₂ O in the exhaust sample per mole of fuel
P ₅	number of moles of CO in the exhaust sample per mole of fuel
P ₆	number of moles of C _x H _y in the exhaust sample per mole of fuel
P ₇	number of moles of NO ₂ in the exhaust sample per mole of fuel
P ₈	number of moles of NO in the exhaust sample per mole of fuel
P _T	$P_1 + P_2 + P_3 + P_4 + P_5 + P_6 + P_7 + P_8$
[O ₂] _b	gas concentration of O ₂ in dry air, by volume = 0.209 5

$[N_2]_b$	gas concentration of N_2 + rare gases in dry air, by volume = 0.790 2
$[CO_2]_b$	gas concentration of CO_2 in dry air, by volume = 0.000 3
P_0	number of moles of air per mole of fuel in initial air/fuel mixture
Z	symbol used and defined in 3.4
$[CO_2]$	mean gas concentration of CO_2 in exhaust sample, vol/vol, wet
$[CO]$	mean gas concentration of CO in exhaust sample, vol/vol, wet
$[HC]$	mean gas concentration of exhaust hydrocarbons, vol/vol, wet, expressed as carbon
$[NO]$	mean gas concentration of NO in exhaust sample, vol/vol, wet
$[NO_2]$	mean gas concentration of NO_2 in exhaust sample, vol/vol, wet
	$= \frac{([NOx]_c - [NO])}{\eta}$
$[NOx]$	mean gas concentration of NO and NO_2 in exhaust sample, vol/vol, wet = $[NO + NO_2]$
$[NOx]_c$	mean gas concentration of NO in exhaust sample, after passing through the NO_2/NO converter, vol/vol, wet
$[]_d$	mean gas concentration in exhaust sample after cold trap, vol/vol
$[]_m$	mean gas concentration measurement indicated before instrument correction applied, vol/vol
h_{vol}	humidity of ambient air, vol water/vol dry air
h_d	humidity of exhaust sample leaving “drier” or “cold trap”, vol water/vol dry sample
m	number of C atoms in characteristic fuel molecule
n	number of H atoms in characteristic fuel molecule
x	number of C atoms in characteristic exhaust hydrocarbon molecule
y	number of H atoms in characteristic exhaust hydrocarbon molecule
η	efficiency of NO_2/NO converter

2. BASIS OF CALCULATION OF EI AND AFR PARAMETERS

2.1 It is assumed that the balance between the original fuel and air mixture and the resultant state of the exhaust emissions as sampled can be represented by the following equation:

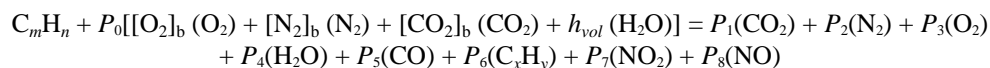

from which the required parameters can, by definition, be expressed as

$$EI(\text{CO}) = P_5 \left(\frac{10^3 M_{\text{CO}}}{mM_{\text{C}} + nM_{\text{H}}} \right)$$

$$EI(\text{HC}) = xP_6 \left(\frac{10^3 M_{\text{HC}}}{mM_{\text{C}} + nM_{\text{H}}} \right) \text{ expressed as methane equivalent}$$

$$EI(\text{NO}_x) = (P_7 + P_8) \left(\frac{10^3 M_{\text{NO}_2}}{mM_{\text{C}} + nM_{\text{H}}} \right) \text{ expressed as NO}_2 \text{ equivalent}$$

$$\text{AFR} = P_0 \left(\frac{M_{\text{AIR}}}{mM_{\text{C}} + nM_{\text{H}}} \right)$$

2.2 Values for fuel hydrocarbon composition (m , n) are assigned by fuel specification or analysis. If only the ratio n/m is so determined, the value $m = 12$ may be assigned. The mole fractions of the dry air constituents ($[\text{O}_2]_{\text{b}}$, $[\text{N}_2]_{\text{b}}$, $[\text{CO}_2]_{\text{b}}$) are normally taken to be the recommended standard values but alternative values may be assigned, subject to the restriction $[\text{O}_2]_{\text{b}} + [\text{N}_2]_{\text{b}} + [\text{CO}_2]_{\text{b}} = 1$ and the approval of the certificating authority.

2.3 The ambient air humidity, h_{vol} , is as measured at each test condition. It is recommended that, in the absence of contrary evidence as to the characterization (x , y) of the exhaust hydrocarbon, values of $x = 1$ and $y = 4$ are assigned.

2.4 Determination of the remaining unknowns requires the solution of the following set of linear simultaneous equations, where (1) to (4) derive from the fundamental atomic conservation relationships and (5) to (9) represent the gaseous product gas concentration relationships.

$$m + [\text{CO}_2]_{\text{b}} P_0 = P_1 + P_5 + xP_6 \dots\dots\dots (1)$$

$$n + 2h_{\text{vol}}P_0 = 2P_4 + yP_6 \dots\dots\dots (2)$$

$$(2[\text{O}_2]_{\text{b}} + 2[\text{CO}_2]_{\text{b}} + h_{\text{vol}})P_0 = 2P_1 + 2P_3 + P_4 + P_5 + 2P_7 + P_8 \dots\dots\dots (3)$$

$$2[\text{N}_2]_{\text{b}} P_0 = 2P_2 + P_7 + P_8 \dots\dots\dots (4)$$

$$[\text{CO}_2] P_{\text{T}} = P_1 \dots\dots\dots (5)$$

$$[\text{CO}] P_{\text{T}} = P_5 \dots\dots\dots (6)$$

$$[\text{HC}] P_{\text{T}} = xP_6 \dots\dots\dots (7)$$

$$[\text{NO}_x]_{\text{c}} P_{\text{T}} = \eta P_7 + P_8 \dots\dots\dots (8)$$

$$[\text{NO}] P_{\text{T}} = P_8 \dots\dots\dots (9)$$

$$P_{\text{T}} = P_1 + P_2 + P_3 + P_4 + P_5 + P_6 + P_7 + P_8 \dots\dots\dots (10)$$

The above set of conditional equations is for the case where all measured gas concentrations are true, that is, not subject to interference effects or to the need to correct for sample drying. In practice, interference effects are usually present to a significant degree in the CO and NO measurements, and the option to measure CO_2 and CO on a dry or partially dry basis is often used. The necessary modifications to the relevant equations are described in 2.5 and 2.6.

2.5 The interference effects are mainly caused by the presence of CO₂ and H₂O in the sample which can affect the CO and NO_x analysers in basically different ways. The CO analyser is prone to a zero-shifting effect and the NO_x analyser to a sensitivity change, represented thus:

$$[\text{CO}] = [\text{CO}]_m + L[\text{CO}_2] + M[\text{H}_2\text{O}]$$

$$\text{and } [\text{NO}_x]_c = [\text{NO}_x]_{cm} (1 + L'[\text{CO}_2] + M'[\text{H}_2\text{O}])$$

which transform into the following alternative equations to (6), (8) and (9), when interference effects require to be corrected,

$$[\text{CO}]_m P_T + LP_1 + MP_4 = P_5 \dots\dots\dots (6A)$$

$$[\text{NO}_x]_{cm} (P_T + L'P_1 + M'P_4) = \eta P_7 + P_8 \dots\dots\dots (8A)$$

$$[\text{NO}]_m (P_T + L'P_1 + M'P_4) = P_8 \dots\dots\dots (9A)$$

2.6 The option to measure CO₂ and CO gas concentrations on a dry or partially dry sample basis, that is, with a sample humidity reduced to *h_d*, requires the use of modified conditional equations as follows:

$$[\text{CO}_2]_d (P_T - P_4) (1 + h_d) = P_1 \dots\dots\dots (5A)$$

and

$$[\text{CO}]_d (P_T - P_4) (1 + h_d) = P_5$$

However, the CO analyser may also be subject to interference effects as described in 2.5 and so the complete alternative CO measurement gas concentration equation becomes

$$[\text{CO}]_{md} (P_T - P_4) (1 + h_d) + LP_1 + Mh_d (P_T - P_4) = P_5 \dots\dots\dots (6B)$$

3. ANALYTICAL FORMULATIONS

3.1 General

Equations (1) to (10) can be reduced to yield the analytical formulations for the EI and AFR parameters, as given in 7.1 to this appendix. This reduction is a process of progressive elimination of the roots *P₀*, *P₁* through *P₈*, *P_T*, making the assumptions that all gas concentration measurements are of the “wet” sample and do not require interference corrections or the like. In practice, the option is often chosen to make the CO₂ and CO gas concentration measurements on a “dry” or “semi-dry” basis; also it is often found necessary to make interference corrections. Formulations for use in these various circumstances are given in 3.2, 3.3 and 3.4.

3.2 Equation for conversion of dry gas concentration measurements to wet basis

Gas concentration wet = *K* × gas concentration dry; that is,

$$[] = K []_d$$

The following expression for K applies when CO and CO₂ are determined on a “dry” basis:

$$K = \frac{\{4 + (n/m) [\text{CO}_2]_b + ([n/m] [\text{CO}_2]_b - 2h_{vol}) ([\text{NO}_2] - (2[\text{HC}]/x)) + (2 + h_{vol}) ([y/x] - [n/m]) [\text{HC}]\} (1 + h_d)}{(2 + h) \{2 + (n/m) (1 + h_d) ([\text{CO}_2]_d + [\text{CO}]_d)\} - ([n/m] [\text{CO}_2]_b - 2h) (1 - [1 + h_d] [\text{CO}]_d)}$$

3.3 Interference corrections

The measurements of CO and/or NO_x and NO may require corrections for interference by the sample CO₂ and water concentrations before use in the above analytical equations. Such corrections can normally be expressed in the following general ways:

$$[\text{CO}] = [\text{CO}]_m + L[\text{CO}_2] + M[\text{H}_2\text{O}]$$

$$[\text{CO}]_d = [\text{CO}]_{md} + L[\text{CO}_2]_d + M \left(\frac{h_d}{1 + h_d} \right)$$

$$[\text{NO}] = [\text{NO}]_m (1 + L'[\text{CO}_2] + M'[\text{H}_2\text{O}])$$

$$\eta[\text{NO}_2] = ([\text{NO}_x]_{cm} - [\text{NO}]_m) (1 + L'[\text{CO}_2] + M'[\text{H}_2\text{O}])$$

3.4 Equation for estimation of sample water content

Water concentration in sample

$$[\text{H}_2\text{O}] = \frac{([n/2m] + h_{vol} [P_0/m]) ([\text{CO}_2] + [\text{CO}] + [\text{HC}])}{1 + [\text{CO}_2]_b (P_0/m)} - (y/2x)[\text{HC}]$$

where

$$P_0/m = \frac{2Z - n/m}{4(1 + h_{vol} - [TZ/2])}$$

and

$$Z = \frac{2 - [\text{CO}] - ([2/x] - [y/2x])[\text{HC}] + [\text{NO}_2]}{[\text{CO}_2] + [\text{CO}] + [\text{HC}]}$$

It should be noted that this estimate is a function of the various analyses gas concentration readings, which may themselves require water interference correction. For better accuracy an iterative procedure is required in these cases with successive recalculation of the water concentration until the requisite stability is obtained. The use of the alternative, numerical solution methodology (4) avoids this difficulty.

4. ALTERNATIVE METHODOLOGY — NUMERICAL SOLUTION

4.1 As an alternative to the analytical procedures summarized in 3, it is possible to obtain readily the emissions indices, fuel/air ratio, corrected wet gas concentrations, etc., by a numerical solution of equations (1) to (10) for each set of measurements, using a digital computer.

4.2 In the equation set (1) to (10) the actual gas concentration measurements are substituted using whichever of the alternative equations (5A), (6A), etc. applies for the particular measuring system, to take account of interference corrections and/or dried sample measurements.

4.3 Suitable simple two-dimensional array equation-solving computer programmes are widely available and their use for this purpose is convenient and flexible, allowing ready incorporation and identification of any sample drying options and interference or other corrections.

ATTACHMENT F TO APPENDIX 3. SPECIFICATIONS FOR ADDITIONAL DATA

As required in 3.2 of Appendix 3, in addition to the measured sample constituent gas concentrations, the following data shall also be provided:

- a) inlet temperature: measured as the total temperature at a point within one diameter of the engine intake plane to an accuracy of $\pm 0.5^{\circ}\text{C}$;
- b) inlet humidity (kg water/kg dry air): measured at a point within 50 m of the intake plane ahead of the engine to an accuracy of:
 - 1) ± 5 per cent of reading for ambient air humidity greater than or equal to 0.00634 kg water/kg dry air; or
 - 2) ± 0.000317 kg water/kg dry air of reading for ambient air humidity less than 0.00634 kg water/kg dry air;
- c) atmospheric pressure: measured within 1 km of the engine test location and corrected as necessary to the test stand altitude to an accuracy of ± 100 Pa;
- d) fuel mass flow: by direct measurement to an accuracy of ± 2 per cent;
- e) fuel H/C ratio: defined as n/m , where C_mH_n is the equivalent hydrocarbon representation of the fuel used in the test and evaluated by reference to the engine fuel type analysis;
- f) engine parameters:
 - 1) thrust: by direct measurement to an accuracy of ± 1 per cent at take-off power and ± 5 per cent at the minimum thrust used in the certification test, with linear variation between these points;
 - 2) rotation speed(s): by direct measurement to an accuracy of at least ± 0.5 per cent;
 - 3) gas generator airflow: determined to an accuracy of ± 2 per cent by reference to engine performance calibration.

The parameters a), b), d) and f) shall be determined at each engine emissions test setting, while c) shall be determined at intervals of not less than 1 hour over a period encompassing that of the emissions tests.

APPENDIX 4. SPECIFICATION FOR FUEL TO BE USED IN AIRCRAFT TURBINE ENGINE EMISSION TESTING

The fuel shall meet the specifications of this appendix, unless a deviation and any necessary corrections have been agreed upon by the certificating authority. Additives used for the purpose of smoke suppression (such as organometallic compounds) shall not be present.

<i>Property</i>	<i>Allowable range of values</i>
Density kg/m ³ at 15°C	780 – 820
Distillation temperature, °C	
10% boiling point	155 – 201
Final boiling point	235 – 285
Net heat of combustion, MJ/kg	42.86 – 43.50
Aromatics, volume %	15 – 23
Naphthalenes, volume %	0.0 – 3.0
Smoke point, mm	20 – 28
Hydrogen, mass %	13.4 – 14.3
Sulphur, ppm by mass	less than 3 000
Kinematic viscosity at –20°C, mm ² /s	2.5 – 6.5

APPENDIX 5. INSTRUMENTATION AND MEASUREMENT TECHNIQUES FOR GASEOUS EMISSIONS FROM AFTERBURNING GAS TURBINE ENGINES

1. INTRODUCTION

Note.— The procedures specified in this appendix are concerned with the acquisition of representative exhaust samples and their transmission to, and analysis by, the emissions measuring system. These procedures only apply when afterburning is employed. The methods proposed are representative of the best readily available and most established modern practice. The need to correct for ambient conditions is recognized and a method will be specified when one becomes available. Meanwhile any correction methods used when afterburning is employed should be approved by the certificating authority.

Variations in the procedure contained in this appendix shall only be allowed after prior application to and approval by the certificating authority.

2. DEFINITIONS

Where the following expressions are used without further explanation in this appendix, they have the meanings ascribed to them below:

Accuracy. The closeness with which a measurement approaches the true value established independently.

Calibration gas. A high accuracy reference gas to be used for alignment, adjustment and periodic checks of instruments.

Concentration. The volume fraction of the component of interest in the gas mixture — expressed as volume percentage or as parts per million.

Flame ionization detector. A hydrogen-air diffusion flame detector that produces a signal nominally proportional to the mass-flow rate of hydrocarbons entering the flame per unit of time — generally assumed responsive to the number of carbon atoms entering the flame.

Interference. Instrument response due to presence of components other than the gas (or vapour) that is to be measured.

Noise. Random variation in instrument output not associated with characteristics of the sample to which the instrument is responding, and distinguishable from its drift characteristics.

Non-dispersive infrared analyser. An instrument that by absorption of infrared energy selectively measures specific components.

Parts per million (ppm). The unit volume concentration of a gas per million unit volume of the gas mixture of which it is a part.

Parts per million carbon (ppmC). The mole fraction of hydrocarbon multiplied by 10^6 measured on a methane-equivalence basis. Thus, 1 ppm of methane is indicated as 1 ppmC. To convert ppm concentration of any hydrocarbon to an equivalent ppmC value, multiply ppm concentration by the number of carbon atoms per molecule of the gas. For example, 1 ppm propane translates as 3 ppmC hydrocarbon; 1 ppm hexane as 6 ppmC hydrocarbon.

Plume. Total external engine exhaust flow, including any ambient air with which the exhaust mixes.

Reference gas. A mixture of gases of specified and known composition used as the basis for interpreting instrument response in terms of the concentration of the gas to which the instrument is responding.

Repeatability. The closeness with which a measurement upon a given, invariant sample can be reproduced in short-term repetitions of the measurement with no intervening instrument adjustment.

Resolution. The smallest change in a measurement which can be detected.

Response. The change in instrument output signal that occurs with change in sample concentration. Also the output signal corresponding to a given sample concentration.

Stability. The closeness with which repeated measurements upon a given invariant sample can be maintained over a given period of time.

Zero drift. Time-related deviation of instrument output from zero set point when it is operating on gas free of the component to be measured.

Zero gas. A gas to be used in establishing the zero, or no response, adjustment of an instrument.

3. DATA REQUIRED

3.1 Gaseous emissions

Concentrations of the following emissions shall be determined:

- a) Hydrocarbons (HC): a combined estimate of all hydrocarbon compounds present in the exhaust gas.
- b) Carbon monoxide (CO).
- c) Carbon dioxide (CO₂).

Note.— CO₂ is not considered a pollutant but its concentration is required for calculation and check purposes.

- d) Oxides of nitrogen (NO_x): an estimate of the sum of the two oxides, nitric oxide (NO) and nitrogen dioxide (NO₂).
- e) Nitric oxide (NO).

3.2 Other information

In order to normalize the emissions measurement data and to quantify the engine test characteristics, other information in addition to the requirements of Chapter 3, 3.4 shall be provided as follows:

- inlet temperature;
- inlet humidity;
- atmospheric pressure;

- wind vectors relative to engine exhaust axis;
- hydrogen/carbon ratio of fuel;
- engine installation details;
- other required engine parameters (for example, thrust, rotor speeds, turbine temperatures);
- pollutant concentration data and statistical validation parameters.

This data shall be obtained either by direct measurement or by calculation, as presented in Attachment F to this appendix.

4. GENERAL ARRANGEMENT OF THE SYSTEM

Owing to the reactive nature of the exhaust plume from engines using afterburning, it is necessary to ensure that the measured emissions do in fact correspond to those actually emitted into the surrounding atmosphere. This is achieved by sampling the plume sufficiently far downstream from the engine that the exhaust gases have cooled to a temperature where reactions have ceased. No desiccants, dryers, water traps or related equipment shall be used to treat the exhaust sample flowing to the oxides of nitrogen and the hydrocarbon analysis instrumentation. Requirements for the various component subsystems are given in 5, but the following list gives some qualifications and variations:

- a) it is assumed that each of the various individual subsystems includes the necessary flow control, conditioning and measurement facilities;
- b) the necessity for a dump and/or a hot-sample pump will depend on the ability to meet the sample transfer time and analysis subsystem sample flow rate requirements. This in turn depends on the exhaust sample-driving pressure and line losses. It is considered that these pumps usually will be necessary at certain engine running conditions; and
- c) the position of the hot pump, relative to the gas analysis subsystems, may be varied as required. (For example, some HC analysers contain hot pumps and so may be judged capable of being used upstream of the system hot pump.)

Note.— Figures A5-1 and A5-2 are schematic drawings of the exhaust gas sampling and analytical system and typify the basic requirements for emissions testing.

5. DESCRIPTION OF COMPONENT PARTS

Note.— A general description and specification of the principal elements in the engine exhaust emissions measurement system follows. Greater detail, where necessary, will be found in Attachments A, B and C to this appendix.

5.1 Sampling system

5.1.1 Sampling probe

- a) The probe shall be constructed so that individual samples can be withdrawn at various locations across a diameter of the plume. Mixed samples shall not be permitted.
- b) The material with which the sample is in contact shall be stainless steel and its temperature shall be maintained at a value not less than 60°C.

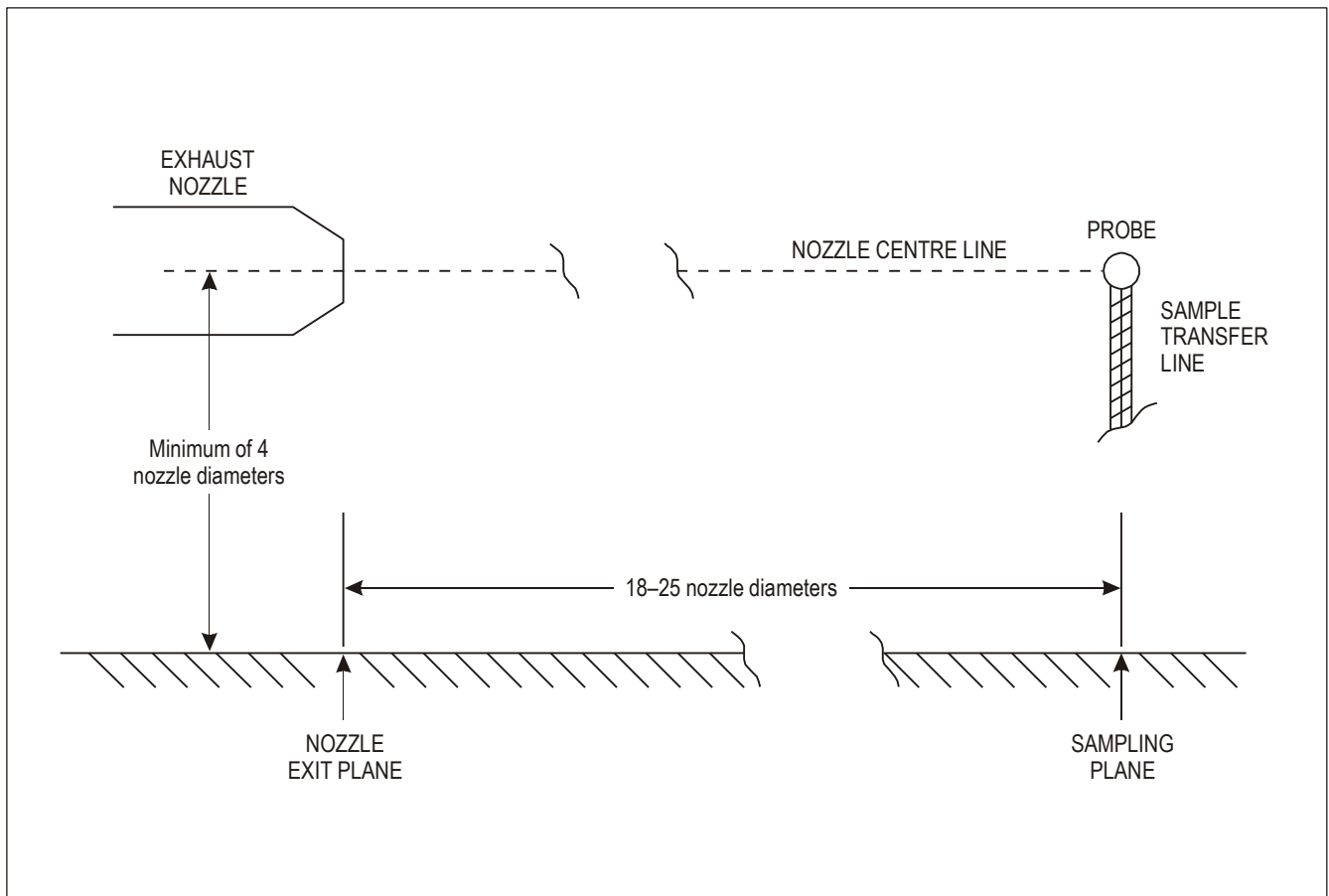

Figure A5-1. Exhaust gas sampling system, schematic

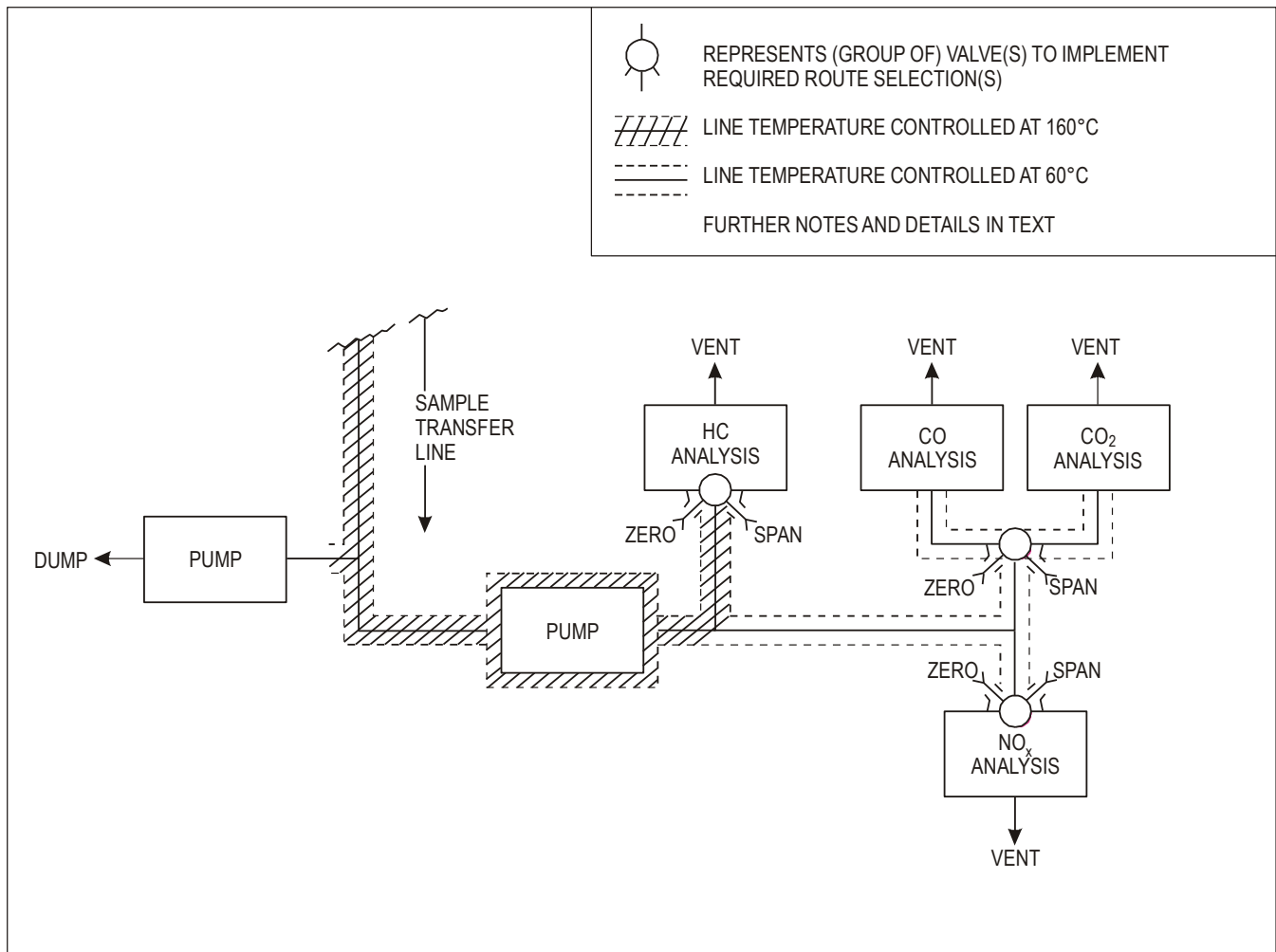

Figure A5-2. Sample transfer and analysis system, schematic

- c) The sampling plane shall be perpendicular to the projected engine nozzle centre line, and shall be situated as close as possible to a position 18 nozzle diameters from the nozzle exit plane, consistent with 7.1.2, but in no case greater than 25 nozzle diameters. The nozzle exit diameter shall be for the maximum engine power condition. Between and including exit and sampling planes there shall be an unobstructed region of at least 4 nozzle exit diameters in radial distance about the project engine nozzle centre line.
- d) The minimum number of sampling points shall be equal to 11. The measurement plane, located at a distance X from the engine shall be divided into three sections demarcated by circles centred around the exhaust stream axis with radii
- $$R1 = 0.05X$$
- $$R2 = 0.09X$$

and a minimum of 3 samples shall be taken from each section. The difference between the number of samples in each section must be less than 3. The sample taken at the most remote distance from the axis shall be from a point located at a radius of between $0.11X$ and $0.16X$.

5.1.2 Sampling lines

The sample shall be transferred from the probe to the analysers via a line of 4.0 to 8.5 mm inside diameter, taking the shortest route practicable and using a flow rate such that the transport time is less than 10 seconds. The line shall be maintained at a temperature of $160^{\circ}\text{C} \pm 15^{\circ}\text{C}$ (with a stability of $\pm 10^{\circ}\text{C}$). When sampling to measure HC, CO, CO₂ and NO_x components, the line shall be constructed in stainless steel or carbon-loaded grounded PTFE.

5.2 HC analyser

The measurement of total hydrocarbon sample content shall be made by an analyser using the heated flame ionization detector (FID), between the electrodes of which passes an ionization current proportional to the mass rate of hydrocarbon entering a hydrogen flame. The analyser shall be deemed to include components arranged to control temperature and flow rates of sample, sample bypass, fuel and diluent gases, and to enable effective span and zero calibration checks.

Note.— An overall specification is given in Attachment A to this appendix.

5.3 CO and CO₂ analysers

Non-dispersive infrared analysers shall be used for the measurement of these components, and shall be of the design which utilizes differential energy absorption in parallel reference and sample gas cells, the cell or group of cells for each of these gas constituents being sensitized appropriately. This analysis subsystem shall include all necessary functions for the control and handling of sample, zero and span gas flows. Temperature control shall be that appropriate to whichever basis of measurement, wet or dry, is chosen.

Note.— An overall specification is given in Attachment B to this appendix.

5.4 NO_x analyser

The measurement of NO concentration shall be by the chemiluminescent method in which the measure of the radiation intensity emitted during the reaction of the NO in the sample with added O₃ is the measure of the NO concentration. The NO₂ component shall be converted to NO in a converter of the requisite efficiency prior to measurement. The resultant NO_x measurement system shall include all necessary flow, temperature and other controls and provide for routine zero and span calibration as well as for converter efficiency checks.

Note.— An overall specification is given in Attachment C to this appendix.

6. GENERAL TEST PROCEDURES

6.1 Engine operation

The engine shall be operated on an open air static test facility which is suitable and properly equipped for high accuracy performance testing, and which conforms to the requirements for sampling probe installation as specified in 5.1. The emissions tests shall be made at the power settings prescribed by the certificating authority. The engine shall be stabilized at each setting.

6.2 Ambient air conditions

6.2.1 A check shall be made on the ambient concentrations of CO, HC, CO₂ and NO_x, with the engine under test running at the test condition. Unusually high concentrations indicate abnormal conditions such as exhaust gas recirculation, fuel spillage or some other source of unwanted emissions in the test area and such situations shall be rectified or avoided as appropriate.

Note.— For guidance, the normal ambient concentration of CO₂ is 0.03 per cent, and ambient concentration levels for CO and HC of 5 ppm and NO_x of 0.5 ppm are unlikely to be exceeded under normal conditions.

6.2.2 Extreme climatic conditions, such as those involving precipitation or excessive wind speed shall also be avoided.

6.3 Major instrument calibration

Note.— The general objective of this calibration is to confirm stability and linearity.

6.3.1 The applicant shall satisfy the certificating authority that the calibration of the analytical system is valid at the time of the test.

6.3.2 For the hydrocarbon analyser this calibration shall include checks that the detector oxygen and differential hydrocarbon responses are within the limits specified in Attachment A to this appendix. The efficiency of the NO₂/NO converter shall also be checked and verified to meet the requirements in Attachment C to this appendix.

6.3.3 The procedure for checking the performance of each analyser shall be as follows (using the calibration and test gases as specified in Attachment D to this appendix):

- a) introduce zero gas and adjust instrument zero, recording setting as appropriate;
- b) for each range to be used operationally, introduce calibration gas of (nominally) 90 per cent range full-scale deflection (FSD) concentration; adjust instrument gain accordingly and record its setting;
- c) introduce approximately 30, 60 and 90 per cent range FSD concentrations and record analyser readings;
- d) fit a least squares straight line to the zero, 30, 60 and 90 per cent concentration points. For the CO and/or CO₂ analyser used in its basic form without linearization of output, a least squares curve of appropriate mathematical formulation shall be fitted using additional calibration points if judged necessary. If any point deviates by more than 2 per cent of the full scale value (or ± 1 ppm*, whichever is greater) then a calibration curve shall be prepared for operational use.

6.4 Operation

6.4.1 No measurements shall be made until all instruments and sample transfer lines are warmed up and stable and the following checks have been carried out:

- a) leakage check: prior to a series of tests the system shall be checked for leakage by isolating the probe and the analysers, connecting and operating a vacuum pump of equivalent performance to that used in the smoke measurement system to verify that the system leakage flow rate is less than 0.4 L/min referred to normal temperature and pressure;

* Except for the CO₂ analyser, for which the value shall be ± 100 ppm.

- b) cleanliness check: isolate the gas sampling system from the probe and connect the end of the sampling line to a source of zero gas. Warm the system up to the operational temperature needed to perform hydrocarbon measurements. Operate the sample flow pump and set the flow rate to that used during engine emission testing. Record the hydrocarbon analyser reading. The reading shall not exceed 1 per cent of the engine idle emission level or 1 ppm (both expressed as methane), whichever is the greater.

Note 1.— It is good practice to back-purge the sampling lines during engine running, while the probe is in the engine exhaust but emissions are not being measured, to ensure that no significant contamination occurs.

Note 2.— It is also good practice to monitor the inlet air quality at the start and end of testing and at least once per hour during a test. If levels are considered significant, then they should be taken into account.

6.4.2 The following procedure shall be adopted for operational measurements:

- a) apply appropriate zero gas and make any necessary instrument adjustments;
- b) apply appropriate calibration gas at a nominal 90 per cent FSD concentration for the ranges to be used, adjust and record gain settings accordingly;
- c) when the engine has been stabilized at the requisite operating conditions and sampling location, continue to run it and observe pollutant concentrations until a stabilized reading is obtained, which shall be recorded. At the same engine operating condition repeat the measurement procedure for each of the remaining sampling locations;
- d) recheck zero and calibration points at the end of the test and also at intervals not greater than 1 hour during tests. If either has changed by more than ± 2 per cent of full scale of range, the test shall be repeated after restoration of the instrument to within its specification.

7. CALCULATIONS

7.1 Gaseous emissions

7.1.1 General

The analytical measurements made shall be the concentrations of the various classes of pollutant, at the relevant afterburning mode(s) of the engine, at the various locations in the sampling plane. In addition to the recording of these basic parameters, other parameters shall be computed and reported, as follows.

7.1.2 Analysis and validation of measurements

- a) At each engine setting, the concentrations measured at different probe sampling positions must be averaged as follows:

$$C_{i \text{ moy}} = \sum_{j=1}^n C_{i \text{ j}}$$

where

$\sum_{j=1}^n$ Summation of the total number n of sampling positions used.

C_{ij} Concentration of species i measured at the j th sampling position.

$C_{i\text{ moy}}$ average or mean concentration of species i .

All dry concentration measurements shall be converted into real wet concentrations. (See Attachment E to this appendix).

- b) The quality of the measurements for each pollutant will be determined through a comparison with measurements of CO_2 using the correlation coefficient:

$$r_i = \frac{n \sum_{j=1}^n C_{ij} \text{CO}_{2j} - \sum_{j=1}^n C_{ij} \sum_{j=1}^n \text{CO}_{2j}}{\sqrt{\left(\left\{ n \sum_{j=1}^n (\text{CO}_{2j})^2 - \left(\sum_{j=1}^n \text{CO}_{2j} \right)^2 \right\} \left\{ n \sum_{j=1}^n C_{ij}^2 - \left(\sum_{j=1}^n C_{ij} \right)^2 \right\} \right)}}$$

Values of r_i which are near to 1 indicate that measurements taken over the entire sampling period are sufficiently stable and that the curves are Gaussian. In the event that r_i is less than 0.95, measurements must be repeated in a sampling plane located at a more remote distance from the aircraft engine. The measurement process, per se, is then followed by the same calculations and the same demonstration as previously.

7.1.3 Basic parameters

For the measurements at each engine operating mode the average concentration for each gaseous species is estimated as shown in 7.1.2, any necessary corrections for dry sample measurement and/or interferences having been made as indicated in Attachment E to this appendix. These average concentrations are used to compute the following basic parameters:

$$\text{EI}_p \text{ (emission index for component } p) = \frac{\text{mass of } p \text{ produced in g}}{\text{mass of fuel used in kg}}$$

$$\text{EI}(\text{CO}) = \left(\frac{[\text{CO}]}{[\text{CO}_2] + [\text{CO}] + [\text{HC}]} \right) \left(\frac{10^3 M_{\text{CO}}}{M_{\text{C}} + (n/m)M_{\text{H}}} \right) (1+T(\text{P}_0/m))$$

$$\text{EI}(\text{HC}) = \left(\frac{[\text{HC}]}{[\text{CO}_2] + [\text{CO}] + [\text{HC}]} \right) \left(\frac{10^3 M_{\text{HC}}}{M_{\text{C}} + (n/m)M_{\text{H}}} \right) (1+T(\text{P}_0/m))$$

$$\text{EI}(\text{NO}_x) \text{ (as NO}_2) = \left(\frac{[\text{NO}_x]}{[\text{CO}_2] + [\text{CO}] + [\text{HC}]} \right) \left(\frac{10^3 M_{\text{NO}_2}}{M_{\text{C}} + (n/m)M_{\text{H}}} \right) (1+T(\text{P}_0/m))$$

$$\text{Air/fuel ratio} = (\text{P}_0/m) \left(\frac{M_{\text{AIR}}}{M_{\text{C}} + (n/m)M_{\text{H}}} \right)$$

where

$$P_0/m = \frac{2Z - (n/m)}{4(1 + h_{vol} - [TZ/2])}$$

and

$$Z = \frac{2 - [\text{CO}] - ([2/x] - [y/2x])[\text{HC}] + [\text{NO}_2]}{[\text{CO}_2] + [\text{CO}] + [\text{HC}]}$$

M_{AIR} molecular mass of dry air = 28.966 g or, where appropriate, = (32 R + 28.156 4 S + 44.011 T) g

M_{HC} molecular mass of exhaust hydrocarbons, taken as CH_4 = 16.043 g

M_{CO} molecular mass of CO = 28.011 g

M_{NO_2} molecular mass of NO_2 = 46.088 g

M_{C} atomic mass of carbon = 12.011 g

M_{H} atomic mass of hydrogen = 1.008 g

R concentration of O_2 in dry air, by volume = 0.209 5 normally

S concentration of N_2 + rare gases in dry air, by volume = 0.709 2 normally

T concentration of CO_2 in dry air, by volume = 0.000 3 normally

[HC] mean concentration of exhaust hydrocarbons vol/vol, wet, expressed as carbon

[CO] mean concentration of CO vol/vol, wet

[CO_2] mean concentration of CO_2 vol/vol, wet

[NO_x] mean concentration of NO_x vol/vol, wet = [NO + NO_2]

[NO] mean concentration of NO in exhaust sample, vol/vol, wet

[NO_2] mean concentration of NO_2 in exhaust sample, vol/vol, wet

$$= \frac{([\text{NO}_x]_c - [\text{NO}])}{\eta}$$

[NO_x]_c mean concentration of NO in exhaust sample after passing through the NO_2/NO converter, vol/vol, wet

η efficiency of NO_2/NO converter

h_{vol} humidity of ambient air, vol water/vol dry air

m number of C atoms in characteristic fuel molecule

n	number of H atoms in characteristic fuel molecule
x	number of C atoms in characteristic exhaust hydrocarbon molecule
y	number of H atoms in characteristic exhaust hydrocarbon molecule

The value of n/m , the ratio of the atomic hydrogen to atomic carbon of fuel used, is evaluated by fuel type analysis. The ambient air humidity, h , shall be measured at each set condition. In the absence of contrary evidence as to the characterization (x, y) of the exhaust hydrocarbons, the values $x = 1$, $y = 4$ are to be used. If dry or semi-dry CO and CO₂ measurements are to be used then these shall first be converted to the equivalent wet concentrations as shown in Attachment E to this appendix, which also contains interference correction formulas for use as required.

Note.— The procedure given in 7.1.4 and 7.2 is only applicable to tests made when afterburning is not used. For tests when afterburning is used, a similar procedure could be used after approval by the certifying authority.

7.1.4 Correction of emission indices to reference conditions

Corrections shall be made to the measured engine emission indices for all pollutants in all relevant engine operating modes to account for deviations from the reference conditions (ISA at sea level) of the actual test inlet air conditions of temperature and pressure. The reference value for humidity shall be 0.00634 kg water/kg dry air.

Thus, EI corrected = $K \times$ EI measured,

where the generalized expression for K is:

$$K = (P_{Bref}/P_B)^a \times (FAR_{ref}/FAR_B)^b \times \exp [(T_{Bref} - T_B)/c] \times \exp (d[h_{vol} - 0.00634])$$

P_B	Combustor inlet pressure, measured
T_B	Combustor inlet temperature, measured
FAR_B	Fuel/air ratio in the combustor
h_{vol}	Ambient air humidity, vol water/vol dry air
P_{ref}	ISA sea level pressure
T_{ref}	ISA sea level temperature
P_{Bref}	Pressure at the combustor inlet of the engine tested (or the reference engine if the data is corrected to a reference engine) associated with T_B under ISA sea level conditions.
T_{Bref}	Temperature at the combustor inlet under ISA sea level conditions for the engine tested (or the reference engine if the data is to be corrected to a reference engine). This temperature is the temperature associated with each thrust level specified for each mode.
FAR_{ref}	Fuel/air ratio in the combustor under ISA sea level conditions for the engine tested (or the reference engine if the data is to be corrected to a reference engine).
a, b, c, d	Specific constants which may vary for each pollutant and each engine type.

The combustor inlet parameters shall preferably be measured but may be calculated from ambient conditions by appropriate formulas.

7.1.5 Using the recommended curve fitting technique to relate emission indices to combustor inlet temperature effectively eliminates the $\exp((T_{Bref} - T_B)/c)$ term from the generalized equation and for most cases the (FAR_{ref}/FAR_B) term may be considered unity. For the emissions indices of CO and HC many testing facilities have determined that the humidity term is sufficiently close to unity to be eliminated from the expression and that the exponent of the (P_{Bref}/P_B) term is close to unity.

Thus,

EI(CO) corrected = EI derived from $(P_B/P_{Bref}) \nabla$ EI(CO) v. T_B curve

EI(HC) corrected = EI derived from $(P_B/P_{Bref}) \nabla$ EI(HC) v. T_B curve

EI(NOx) corrected = EI derived from EI(NOx) $(P_{Bref}/P_B)^{0.5 \exp(19[h_{vol} - 0.00634])}$ v. T_B curve

If this recommended method for the CO and HC emissions index correction does not provide a satisfactory correlation, an alternative method using parameters derived from component tests may be used.

Any other methods used for making corrections to CO, HC and NOx emissions indices shall have the approval of the certificating authority.

7.2 Control parameter functions

(D_p, F_{oo}, π)

7.2.1 Definitions

- D_p The mass of any gaseous pollutant emitted during the reference emissions landing and take-off cycle.
- F_{oo} The maximum thrust available for take-off under normal operating conditions at ISA sea level static conditions, without the use of water injection, as approved by the applicable certificating authority.
- π The ratio of the mean total pressure at the last compressor discharge plane of the compressor to the mean total pressure at the compressor entry plane when the engine is developing take-off thrust rating at ISA sea level static conditions.

7.2.2 The emission indices (EI) for each pollutant, corrected for pressure and humidity (as appropriate) to the reference ambient atmospheric conditions as indicated in 7.1.4 and if necessary to the reference engine, shall be obtained for the required LTO engine operating mode settings (n) of idle, approach, climb-out and take-off, at each of the equivalent corrected thrust conditions. A minimum of three test points shall be required to define the idle mode. The following relationships shall be determined for each pollutant:

- between EI and T_B ; and
- between W_f (engine fuel mass flow rate) and T_B ; and
- between F_n (corrected to ISA sea level conditions) and T_B (corrected to ISA sea level conditions);

Note.— These are illustrated, for example, by Figure A5-3 a), b) and c).

When the engine being tested is not a “reference” engine, the data may be corrected to “reference” engine conditions using the relationships b) and c) obtained from a reference engine. A reference engine is defined as an engine substantially configured

to the description of the engine to be certificated and accepted by the certifying authority to be representative of the engine type for which certification is sought.

The manufacturer shall also supply to the certifying authority all of the necessary engine performance data to substantiate these relationships and for ISA sea level ambient conditions:

- d) maximum rated thrust (F_{oo}); and
- e) engine pressure ratio (π) at maximum rated thrust.

Note.— These are illustrated by Figure A5-3 d).

7.2.3 The estimation of EI for each pollutant at each of the required engine mode settings, corrected to the reference ambient conditions, shall comply with the following general procedure:

- a) at each mode ISA thrust condition F_n , determine the equivalent combustor inlet temperature (T_B) (Figure A5-3 c));
- b) from the EI/ T_B characteristic (Figure A5-3 a)), determine the EI_n value corresponding to T_B ;
- c) from the W_f/T_B characteristics (Figure A5-3 b)), determine the W_{f_n} value corresponding to T_B ;
- d) note the ISA maximum rated thrust and pressure ratio values. These are F_{oo} and π respectively (Figure A5-3 d));
- e) calculate, for each pollutant $Dp = \Sigma (EI_n) (W_{f_n}) (t)$ where:

t time in LTO mode (minutes)

W_{f_n} fuel mass flow rate (kg/min)

Σ is the summation for the set of modes comprising the reference LTO cycle.

7.2.4 While the methodology described above is the recommended method, the certifying authority may accept equivalent mathematical procedures which utilize mathematical expressions representing the curves illustrated if the expressions have been derived using an accepted curve fitting technique.

7.3 Exceptions to the proposed procedures

In those cases where the configuration of the engine or other extenuating conditions exist which would prohibit the use of this procedure, the certifying authority, after receiving satisfactory technical evidence of equivalent results obtained by an alternative procedure, may approve an alternative procedure.

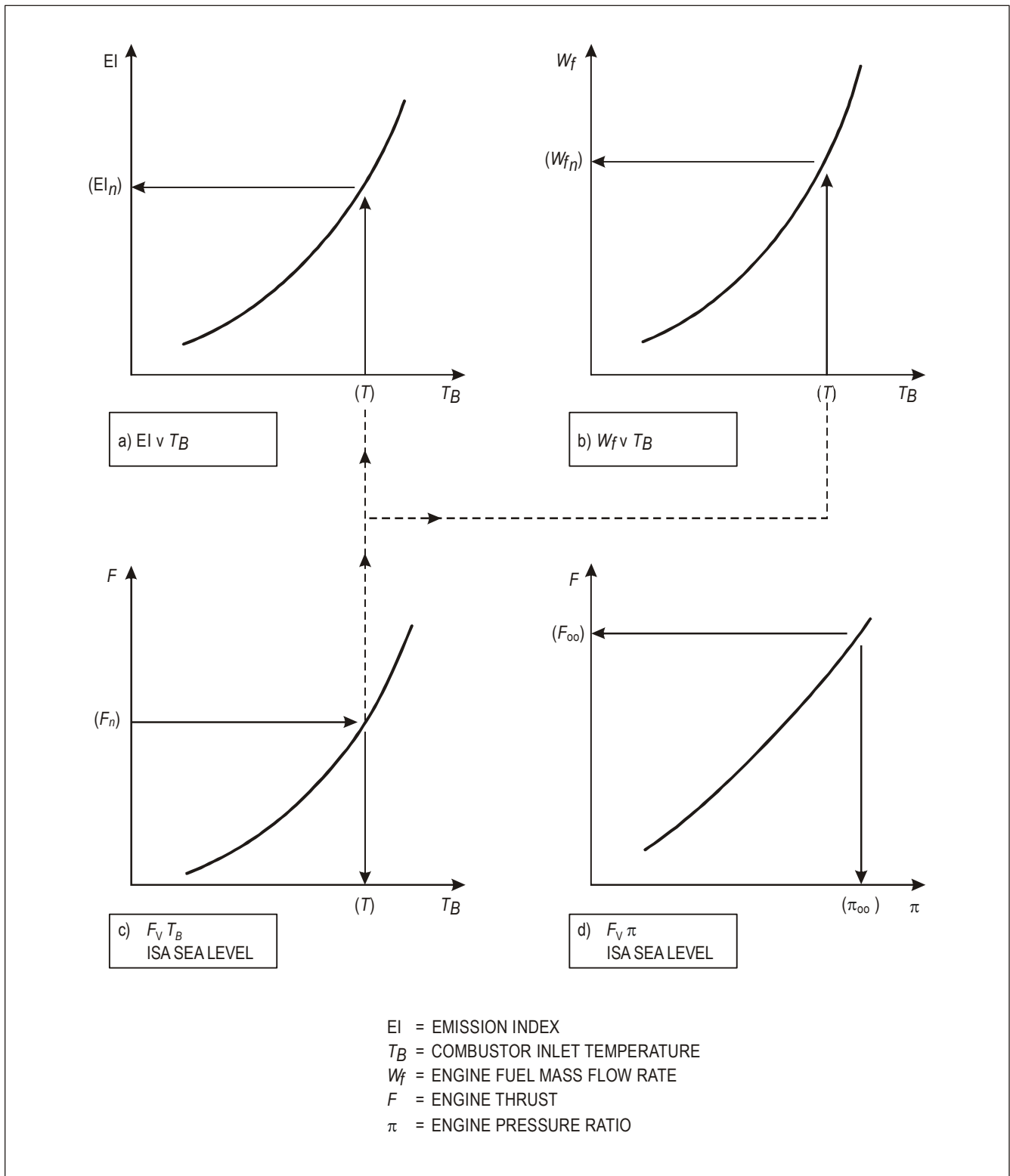

Figure A5-3. Calculation procedure

ATTACHMENT A TO APPENDIX 5. SPECIFICATION FOR HC ANALYSER

Note 1.— As outlined in 5.2 of Appendix 5, the measuring element in this analyser is the flame ionization detector (FID) in which the whole or a representative portion of the sample flow is admitted into a hydrogen-fuelled flame. With suitably positioned electrodes an ionization current can be established which is a function of the mass rate of hydrocarbon entering the flame. It is this current which, referred to an appropriate zero, is amplified and ranged to provide the output response as a measure of the hydrocarbon concentration expressed as ppmC equivalent.

Note 2.— See Attachment D for information on calibration and test gases.

1. GENERAL

Precautions: The performance specifications indicated are generally for analyser full scale. Errors at part scale may be a significantly greater percentage of reading. The relevance and importance of such increases shall be considered when preparing to make measurements. If better performance is necessary, then appropriate precautions shall be taken.

The instrument to be used shall be such as to maintain the temperature of the detector and sample-handling components at a set point temperature within the range 155°C to 165°C to a stability of $\pm 2^\circ\text{C}$. The leading specification points shall be as follows, the detector response having been optimized and the instrument generally having stabilized:

- a) *Total range:* 0 to 500 ppmC in appropriate ranges.
- b) *Resolution:* better than 0.5 per cent of full scale of range used or 0.5 ppmC, whichever is greater.
- c) *Repeatability:* better than ± 1 per cent of full scale of range used, or ± 0.5 ppmC, whichever is greater.
- d) *Stability:* better than ± 2 per cent of full scale of range used or ± 1 ppmC, whichever is greater, in a period of 1 hour.
- e) *Zero drift:* less than ± 1 per cent of full scale of range used or ± 0.5 ppmC, whichever is greater, in a period of 1 hour.
- f) *Noise:* 0.5 Hz and greater, less than ± 1 per cent of full scale of range used or ± 0.5 ppmC, whichever is greater.
- g) *Response time:* shall not exceed 10 seconds from inlet of the sample to the analysis system, to the achievement of 90 per cent of the final reading.
- h) *Linearity:* response with propane in air shall be linear for each range within ± 2 per cent of full scale, otherwise calibration corrections shall be used.

2. SYNERGISTIC EFFECTS

Note.— In application there are two aspects of performance which can affect the accuracy of measurement:

- a) *the oxygen effect (whereby differing proportions of oxygen present in the sample give differing indicated hydrocarbon concentration for constant actual HC concentrations); and*

- b) the relative hydrocarbon response (whereby there is a different response to the same sample hydrocarbon concentrations expressed as equivalent ppmC, dependent on the class or admixture of classes of hydrocarbon compounds).

The magnitude of the effects noted above shall be determined as follows and limited accordingly.

Oxygen response: measure the response with two blends of propane, at approximately 500 ppmC concentration known to a relative accuracy of ± 1 per cent, as follows:

- 1) propane in 10 ± 1 per cent O₂, balance N₂
- 2) propane in 21 ± 1 per cent O₂, balance N₂

If R_1 and R_2 are the respective normalized responses then $(R_1 - R_2)$ shall be less than 3 per cent of R_1 .

Differential hydrocarbon response: measure the response with four blends of different hydrocarbons in air, at concentrations of approximately 500 ppmC, known to a relative accuracy of ± 1 per cent, as follows:

- a) propane in zero air
- b) propylene in zero air
- c) toluene in zero air
- d) n-hexane in zero air.

If R_a , R_b , R_c and R_d are, respectively, the normalized responses (with respect to propane), then $(R_a - R_b)$, $(R_a - R_c)$ and $(R_a - R_d)$ shall each be less than 5 per cent of R_a .

3. OPTIMIZATION OF DETECTOR RESPONSE AND ALIGNMENT

3.1 The manufacturer's instructions for initial setting up procedures and ancillary services and supplies required shall be implemented, and the instrument allowed to stabilize. All setting adjustments shall involve iterative zero checking, and correction as necessary. Using as sample a mixture of approximately 500 ppmC of propane in air, the response characteristics for variations first in fuel flow and then, near an optimum fuel flow, for variations in dilution air flow to select its optimum shall be determined. The oxygen and differential hydrocarbon responses shall then be determined as indicated above.

3.2 The linearity of each analyser range shall be checked by applying propane in air samples at concentrations of approximately 30, 60 and 90 per cent of full scale. The maximum response deviation of any of these points from a least squares straight line (fitted to the points and zero) shall not exceed ± 2 per cent of full scale value. If it does, a calibration curve shall be prepared for operational use.

ATTACHMENT B TO APPENDIX 5. SPECIFICATION FOR CO AND CO₂ ANALYSERS

Note 1.— Paragraph 5.3 of Appendix 5 summarizes the characteristics of the analysis subsystem to be employed for the individual measurements of CO and CO₂ concentrations in the exhaust gas sample. The instruments are based on the principle of non-dispersive absorption of infrared radiation in parallel reference and sample gas cells. The required ranges of sensitivity are obtained by use of stacked sample cells or changes in electronic circuitry or both. Interferences from gases with overlapping absorption bands may be minimized by gas absorption filters and/or optical filters, preferably the latter.

Note 2.— See Attachment D for information on calibration and test gases.

Precautions: The performance specifications indicated are generally for analyser full scale. Errors at part scale may be a significantly greater percentage of reading. The relevance and importance of such increases shall be considered when preparing to make measurements. If better performance is necessary, then appropriate precautions shall be taken.

The principal performance specification shall be as follows:

CO Analyser

- a) *Total range:* 0 to 2 500 ppm in appropriate ranges.
- b) *Resolution:* better than 0.5 per cent of full scale of range used or 1 ppm, whichever is greater.
- c) *Repeatability:* better than ± 1 per cent of full scale of range used, or ± 2 ppm, whichever is greater.
- d) *Stability:* better than ± 2 per cent of full scale of range used or ± 2 ppm, whichever is greater, in a period of 1 hour.
- e) *Zero drift:* less than ± 1 per cent of full scale of range used or ± 2 ppm, whichever is greater, in a period of 1 hour.
- f) *Noise:* 0.5 Hz and greater, less than ± 1 per cent of full scale of range used or ± 1 ppm, whichever is greater.
- g) *Interferences:* to be limited with respect to indicated CO concentration as follows:
 - 1) less than 500 ppm/per cent ethylene concentration
 - 2) less than 2 ppm/per cent CO₂ concentration
 - 3) less than 2 ppm/per cent water vapour.*

If the interference limitation(s) for CO₂ and/or water vapour cannot be met, appropriate correction factors shall be determined, reported and applied.

Note.— It is recommended as consistent with good practice that such correction procedures be adopted in all cases.

* Need not apply where measurements are on a “dry” basis.

CO₂ Analyser

- a) *Total range*: 0 to 10 per cent in appropriate ranges.
- b) *Resolution*: better than 0.5 per cent of full scale of range used or 100 ppm, whichever is greater.
- c) *Repeatability*: better than ± 1 per cent of full scale of range used or ± 100 ppm, whichever is greater.
- d) *Stability*: better than ± 2 per cent of full scale of range used or ± 100 ppm, whichever is greater, in a period of 1 hour.
- e) *Zero drift*: less than ± 1 per cent of full scale of range used or ± 100 ppm, whichever is greater, in a period of 1 hour.
- f) *Noise*: 0.5 Hz and greater, less than ± 1 per cent of full scale of range used or ± 100 ppm, whichever is greater.
- g) The effect of oxygen (O₂) on the CO₂ analyser response shall be checked. For a change from 0 per cent O₂ to 21 per cent O₂ the response of a given CO₂ concentration shall not change by more than 2 per cent of reading. If this limit cannot be met an appropriate correction factor shall be applied.

Note.— *It is recommended as consistent with good practice that such correction procedures be adopted in all cases.*

CO and CO₂ Analysers

- a) *Response time*: shall not exceed 10 seconds from inlet of the sample to the analysis system, to the achievement of 90 per cent of the final reading.
- b) *Sample temperature*: the normal mode of operation is for analysis of the sample in its (untreated) “wet” condition. This requires that the sample cell and all other components in contact with the sample in this subsystem be maintained at a temperature of not less than 50°C, with a stability of $\pm 2^\circ\text{C}$. The option to measure CO and CO₂ on a dry basis (with suitable water traps) is allowed, in which case unheated analysers are permissible and the interference limits for H₂O vapour removed, and subsequent correction for inlet water vapour and water of combustion is required.
- c) *Calibration curves*:
 - i) Analysers with a linear signal output characteristic shall be checked on all working ranges using calibration gases at known concentrations of approximately 0, 30, 60 and 90 per cent of full scale. The maximum response deviation of any of these points from a least squares straight line, fitted to the points and the zero reading, shall not exceed ± 2 per cent of the full scale value. If it does then a calibration curve shall be prepared for operational use.
 - ii) Analysers with a non-linear signal output characteristic, and those that do not meet the requirements of linearity given above, shall have calibration curves prepared for all working ranges using calibration gases at known concentrations of approximately 0, 30, 60 and 90 per cent of full scale. Additional mixes shall be used, if necessary, to define the curve shape properly.

ATTACHMENT C TO APPENDIX 5. SPECIFICATION FOR NO_x ANALYSER

Note.— See Attachment D for information on calibration and test gases.

1. As indicated in 5.4 of Appendix 5, the measurement of the oxides of nitrogen concentration shall be by the chemiluminescent technique in which radiation emitted by the reaction of NO and O₃ is measured. This method is not sensitive to NO₂ and therefore the sample shall be passed through a converter in which NO₂ is converted to NO before the measurement of total NO_x is made. Both the original NO and the total NO_x concentrations shall be recorded. Thus by difference, a measure of the NO₂ concentration shall be obtained.

2. The instrument to be used shall be complete with all necessary flow control components, such as regulators, valves, flowmeters, etc. Materials in contact with the sample gas shall be restricted to those which are resistant to attack by oxides of nitrogen, such as stainless steel, glass, etc. The temperature of the sample shall everywhere be maintained at values, consistent with the local pressures, which avoid condensation of water.

Precautions: The performance specifications indicated are generally for analyser full scale. Errors at part scale may be a significantly greater percentage of reading. The relevance and importance of such increases shall be considered when preparing to make measurements. If better performance is necessary, then appropriate precautions shall be taken.

3. The principal performance specification, determined for the instrument operated in an ambient temperature stable to within 2°C, shall be as follows:

- a) *Total range:* 0 to 2 500 ppm in appropriate ranges.
- b) *Resolution:* better than 0.5 per cent of full scale of range used or 1 ppm, whichever is greater.
- c) *Repeatability:* better than ±1 per cent of full scale of range used, or ±1 ppm, whichever is greater.
- d) *Stability:* better than ±2 per cent of full scale of range used or ±1 ppm, whichever is greater, in a period of 1 hour.
- e) *Zero drift:* less than ±1 per cent of full scale of range used or ±1 ppm, whichever is greater, in a period of 1 hour.
- f) *Noise:* 0.5 Hz and greater, less than ±1.0 per cent of full scale of range used or ±1 ppm, whichever is greater, in a period of 2 hours.
- g) *Interference:* suppression for samples containing CO₂ and water vapour, shall be limited as follows:
 - less than 0.05 per cent reading/per cent CO₂ concentration;
 - less than 0.1 per cent reading/per cent water vapour concentration.

If the interference limitation(s) for CO₂ and/or water vapour cannot be met, appropriate correction factors shall be determined, reported and applied.

Note.— It is recommended as consistent with good practice that such correction procedures be adopted in all cases.

- h) *Response time*: shall not exceed 10 seconds from inlet of the sample to the analysis system to the achievement of 90 per cent of the final reading.
- i) *Linearity*: better than ± 2 per cent of full scale of range used or ± 2 ppm, whichever is greater.
- j) *Converter*: this shall be designed and operated in such a matter as to reduce NO_2 present in the sample to NO. The converter shall not affect the NO originally in the sample.

The converter efficiency shall not be less than 90 per cent.

This efficiency value shall be used to correct the measured sample NO_2 value (i.e. $[\text{NOx}]_c - [\text{NO}]$) to that which would have been obtained if the efficiency had not been 100 per cent.

ATTACHMENT D TO APPENDIX 5. CALIBRATION AND TEST GASES

Table of calibration gases

<i>Analyser</i>	<i>Gas</i>	<i>Accuracy*</i>
HC	propane in zero air	±2 per cent or ±0.05 ppm**
CO ₂	CO ₂ in zero air	±2 per cent or ±100 ppm**
CO	CO in zero air	±2 per cent or ±2 ppm**
NO _x	NO _x in zero nitrogen	±2 per cent or ±1 ppm**

* Taken over the 95 per cent confidence interval.
 ** Whichever is greater.

The above gases are required to carry out the routine calibration of analysers during normal operational use.

Table of test gases

<i>Analyser</i>	<i>Gas</i>	<i>Accuracy*</i>
HC	propane in 10 ±1 per cent O ₂ balance zero nitrogen	±1 per cent
HC	propane in 21 ±1 per cent O ₂ balance zero nitrogen	±1 per cent
HC	propylene in zero air	±1 per cent
HC	toluene in zero air	±1 per cent
HC	n-hexane in zero air	±1 per cent
HC	propane in zero air	±1 per cent
CO ₂	CO ₂ in zero air	±1 per cent
CO ₂	CO ₂ in zero nitrogen	±1 per cent
CO	CO in zero air	±1 per cent
NO _x	NO in zero nitrogen	±1 per cent

* Taken over the 95 per cent confidence interval.

The above gases are required to carry out the tests of Attachments A, B and C.

Carbon monoxide and carbon dioxide calibration gases may be blended singly or as dual component mixtures. Three component mixtures of carbon monoxide, carbon dioxide and propane in zero air may be used, provided the stability of the mixture is assured.

Zero gas as specified for the CO, CO₂ and HC analysers shall be zero air (which includes “artificial” air with 20 to 22 per cent O₂ blended with N₂). For the NO_x analyser zero nitrogen shall be used as the zero gas. Impurities in both kinds of zero gas shall be restricted to be less than the following concentrations:

- 1 ppm C
- 1 ppm CO
- 100 ppm CO₂
- 1 ppm NO_x

The applicant shall ensure that commercial gases, as supplied, do in fact meet this specification, or are so specified by the vendor.

**ATTACHMENT E TO APPENDIX 5. THE CALCULATION OF THE
EMISSIONS PARAMETERS — BASIS, MEASUREMENT
CORRECTIONS AND ALTERNATIVE NUMERICAL METHOD**

1. SYMBOLS

<i>AFR</i>	air/fuel ratio; the ratio of the mass flow rate of dry air to that of the fuel
<i>EI</i>	emission index; $10^3 \times$ mass flow rate of gaseous emission product in exhaust per unit mass flow rate of fuel
<i>K</i>	ratio of concentration measured wet to that measured dry (after cold trap)
<i>L, L'</i>	analyser interference coefficient for interference by CO ₂
<i>M, M'</i>	analyser interference coefficient for interference by H ₂ O
<i>M_{AIR}</i>	molecular mass of dry air = 28.966 g or, where appropriate, = (32 <i>R</i> + 28.156 4 <i>S</i> + 44.011 <i>T</i>) g
<i>M_{CO}</i>	molecular mass of CO = 28.011 g
<i>M_{HC}</i>	molecular mass of exhaust hydrocarbon, taken as CH ₄ = 16.043 g
<i>M_{NO₂}</i>	molecular mass of NO ₂ = 46.008 g
<i>M_C</i>	atomic mass of carbon = 12.011 g
<i>M_H</i>	atomic mass of hydrogen = 1.008 g
<i>P₁</i>	number of moles of CO ₂ in the exhaust sample per mole of fuel
<i>P₂</i>	number of moles of N ₂ in the exhaust sample per mole of fuel
<i>P₃</i>	number of moles of O ₂ in the exhaust sample per mole of fuel
<i>P₄</i>	number of moles of H ₂ O in the exhaust sample per mole of fuel
<i>P₅</i>	number of moles of CO in the exhaust sample per mole of fuel
<i>P₆</i>	number of moles of C _{<i>x</i>} H _{<i>y</i>} in the exhaust sample per mole of fuel
<i>P₇</i>	number of moles of NO ₂ in the exhaust sample per mole of fuel
<i>P₈</i>	number of moles of NO in the exhaust sample per mole of fuel
<i>P_T</i>	$P_1 + P_2 + P_3 + P_4 + P_5 + P_6 + P_7 + P_8$
<i>R</i>	concentration of O ₂ in dry air, by volume = 0.2095 normally

S	concentration of N_2 + rare gases in dry air, by volume = 0.7902 normally
T	concentration of CO_2 in dry air, by volume = 0.0003 normally
P_0	number of moles of air per mole of fuel in initial air/fuel mixture
Z	symbol used and defined in 3.4
$[CO_2]$	mean concentration of CO_2 in exhaust sample, vol/vol
$[CO]$	mean concentration of CO in exhaust sample, vol/vol
$[HC]$	mean concentration of HC in exhaust sample, vol/vol
$[NO]$	mean concentration of NO in exhaust sample, vol/vol
$[NO_2]$	mean concentration of NO_2 in exhaust sample, vol/vol
$[NOx]$	mean concentration of NO and NO_2 in exhaust sample, vol/vol
$[NOx]_c$	mean concentration of NO in exhaust sample, after passing through the NO_2/NO converter, vol/vol
$[NO_2]$	mean = $\frac{([NOx]_c - [NO])}{\eta}$
$[]_d$	mean concentration in exhaust sample after cold trap, vol/vol
$[]_m$	mean concentration measurement indicated before instrument correction applied, vol/vol
h_{vol}	humidity of ambient air, vol water/vol dry air
h_d	humidity of exhaust sample leaving “drier” or “cold trap”, vol water/vol dry sample
m	number of C atoms in characteristic fuel molecule
n	number of H atoms in characteristic fuel molecule
x	number of C atoms in characteristic exhaust hydrocarbon molecule
y	number of H atoms in characteristic exhaust hydrocarbon molecule
η	efficiency of NO_2/NO converter

2. BASIS OF CALCULATION OF EI AND AFR PARAMETERS

2.1 It is assumed that the balance between the original fuel and air mixture and the resultant state of the exhaust emissions as sampled can be represented by the following equation:

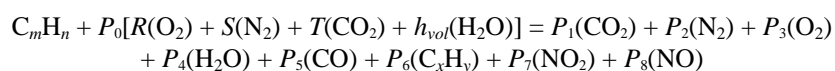

from which the required parameters can, by definition, be expressed as

$$EI(\text{CO}) = P_5 \left(\frac{10^3 M_{\text{CO}}}{mM_{\text{C}} + nM_{\text{H}}} \right)$$

$$EI(\text{HC}) = xP_6 \left(\frac{10^3 M_{\text{HC}}}{mM_{\text{C}} + nM_{\text{H}}} \right) \text{ expressed as methane equivalent}$$

$$EI(\text{NO}_x) = (P_7 + P_8) \left(\frac{10^3 M_{\text{NO}_2}}{mM_{\text{C}} + nM_{\text{H}}} \right) \text{ expressed as NO}_2 \text{ equivalent}$$

$$\text{AFR} = P_0 \left(\frac{M_{\text{AIR}}}{mM_{\text{C}} + nM_{\text{H}}} \right)$$

2.2 Values for fuel hydrocarbon composition (m , n) are assigned by fuel specification or analysis. If only the ratio n/m is so determined, the value $m = 12$ may be assigned. The mole fractions of the dry air constituents (R , S , T) are normally taken to be the recommended standard values but alternative values may be assigned, subject to the restriction $R + S + T = 1$ and the approval of the certifying authority.

2.3 The ambient air humidity, h_{vol} , is as measured at each test condition. It is recommended that, in the absence of contrary evidence as to the characterization (x , y) of the exhaust hydrocarbon, values of $x = 1$ and $y = 4$ are assigned.

2.4 Determination of the remaining unknowns requires the solution of the following set of linear simultaneous equations, where (1) to (4) derive from the fundamental atomic conservation relationships and (5) to (9) represent the gaseous product concentration relationships.

$$m + TP_0 = P_1 + P_5 + xP_6 \dots\dots\dots (1)$$

$$n + 2hP_0 = 2P_4 + yP_6 \dots\dots\dots (2)$$

$$(2R + 2T + h_{\text{vol}})P_0 = 2P_1 + 2P_3 + P_4 + P_5 + 2P_7 + P_8 \dots\dots\dots (3)$$

$$2SP_0 = 2P_2 + P_7 + P_8 \dots\dots\dots (4)$$

$$[\text{CO}_2] P_{\text{T}} = P_1 \dots\dots\dots (5)$$

$$[\text{CO}] P_{\text{T}} = P_5 \dots\dots\dots (6)$$

$$[\text{HC}] P_{\text{T}} = xP_6 \dots\dots\dots (7)$$

$$[\text{NO}_x] P_{\text{T}} = \eta P_7 + P_8 \dots\dots\dots (8)$$

$$[\text{NO}] P_{\text{T}} = P_8 \dots\dots\dots (9)$$

$$P_{\text{T}} = P_1 + P_2 + P_3 + P_4 + P_5 + P_6 + P_7 + P_8 \dots\dots\dots (10)$$

The above set of conditional equations is for the case where all measured concentrations are true ones, that is, not subject to interference effects or to the need to correct for sample drying. In practice, interference effects are usually present to a significant degree in the CO, NO_x and NO measurements, and the option to measure CO₂ and CO on a dry or partially dry basis

is often used. The necessary modifications to the relevant equations are described in 2.5 and 2.6.

2.5 The interference effects are mainly caused by the presence of CO₂ and H₂O in the sample which can affect the CO and NO_x analysers in basically different ways. The CO analyser is prone to a zero-shifting effect and the NO_x analyser to a sensitivity change, represented thus:

$$[\text{CO}] = [\text{CP}]_m + L[\text{CO}_2] + M[\text{H}_2\text{O}]$$

and

$$[\text{NO}_x]_c = [\text{NO}_x]_{cm} (1 + L'[\text{CO}_2] + M'[\text{H}_2\text{O}])$$

which transform into the following alternative equations to (6), (8) and (9), when interference effects require to be corrected,

$$[\text{CO}]_m P_T + LP_1 + MP_4 = P_5 \dots\dots\dots (6A)$$

$$[\text{NO}_x]_{cm} (P_T + L'P_1 + M'P_4) = \eta P_7 + P_8 \dots\dots\dots (8A)$$

$$[\text{NO}]_m (P_T + L'P_1 + M'P_4) = P_8 \dots\dots\dots (9A)$$

2.6 The option to measure CO₂ and CO concentrations on a dry or partially dry sample basis, that is, with a sample humidity reduced to h_d , requires the use of modified conditional equations as follows:

$$[\text{CO}_2]_d (P_T - P_4) (1 + h_d) = P_1 \dots\dots\dots (5A)$$

and

$$[\text{CO}]_d (P_T - P_4) (1 + h_d) = P_5$$

However, the CO analyser may also be subject to interference effects as described in 2.5 and so the complete alternative CO measurement concentration equation becomes

$$[\text{CO}]_{md} (P_T - P_4) (1 + h_d) + LP_1 + Mh_d (P_T - P_4) = P_5 \dots\dots\dots (6B)$$

3. ANALYTICAL FORMULATIONS

3.1 General

Equations (1) to (10) can be reduced to yield the analytical formulations for the EI and AFR parameters, as given in 7.1 to this appendix. This reduction is a process of progressive elimination of the roots P_0, P_1 through P_8, P_T , making the assumptions that all concentration measurements are of the “wet” sample and do not require interference corrections or the like. In practice the option is often chosen to make the CO₂ and CO concentration measurements on a “dry” or “semi-dry” basis; also it is often found necessary to make interference corrections. Formulations for use in these various circumstances are given in 3.2, 3.3 and 3.4.

3.2 Equation for conversion of dry concentration measurements to wet basis

Concentration wet = $K \times$ concentration dry; that is,

$$[] = K []_d$$

The following expression for K applies when CO and CO₂ are determined on a “dry” basis:

$$K = \frac{\{4 + (n/m)T + ([n/m]T - 2h_{vol})([NO_2] - (2[HC]/x)) + (2 + h_{vol})([y/x] - [n/m])[HC]\}(1 + h_d)}{(2 + h_{vol})\{2 + (n/m)(1 + h_d)([CO_2]_d + [CO]_d)\} - ([n/m]T - 2h_{vol})(1 - [1 + h_d][CO]_d)}$$

3.3 Interference corrections

The measurements of CO and/or NO_x and NO may require corrections for interference by the sample CO₂ and water concentrations before use in the above analytical equations. Such corrections can normally be expressed in the following general ways:

$$[CO] = [CO]_m + L[CO_2] + M[H_2O]$$

$$[CO]_d = [CO]_{md} + L[CO_2]_d + M \left(\frac{h_d}{1 + h_d} \right)$$

$$[NO] = [NO]_m (1 + L'[CO_2] + M'[H_2O])$$

$$\eta[NO_2] = ([NOx]_{cm} - [NO]_m) (1 + L'[CO_2] + M'[H_2O])$$

3.4 Equation for estimation of sample water content

Water concentration in sample

$$[H_2O] = \frac{([n/2m] + h_{vol}[P_0/m]) ([CO_2] + [CO] + [HC]) - (y/2x) [HC]}{1 + T(P_0/m)}$$

where

$$P_0/m = \frac{2Z - (n/m)}{4(1 + h_{vol} - [TZ/2])}$$

and

$$Z = \frac{2 - [CO] - ([2/x] - [y/2x]) [HC] + [NO_2]}{[CO_2] + [CO] + [HC]}$$

It should be noted that this estimate is a function of the various analyses concentration readings, which may themselves require water interference correction. For better accuracy an iterative procedure is required in these cases with successive recalculation of the water concentration until the requisite stability is obtained. The use of the alternative, numerical solution methodology (4) avoids this difficulty.

4. ALTERNATIVE METHODOLOGY — NUMERICAL SOLUTION

4.1 As an alternative to the analytical procedures summarized in 3 above, it is possible to obtain readily the emissions

indices, fuel/air ratio, corrected wet concentrations, etc., by a numerical solution of equations (1) to (10) for each set of measurements, using a digital computer.

4.2 In the equation set (1) to (10) the actual concentration measurements are substituted using whichever of the alternative equations (5A), (6A), etc. applies for the particular measuring system, to take account of interference corrections and/or dried sample measurements.

4.3 Suitable simple two-dimensional array equation-solving computer programmes are widely available and their use for this purpose is convenient and flexible, allowing ready incorporation and identification of any sample drying options and interference or other corrections.

ATTACHMENT F TO APPENDIX 5. SPECIFICATIONS FOR ADDITIONAL DATA

As required in 3.2 of Appendix 5, in addition to the measured sample constituent concentrations, the following data shall also be provided:

- a) inlet temperature: measured as the total temperature at a point within one diameter of the engine intake plane to an accuracy of $\pm 0.5^{\circ}\text{C}$;
- b) inlet humidity (kg water/kg dry air): measured at a point within 15 m of the intake plane ahead of the engine to an accuracy of ± 5 per cent of reading;
- c) atmospheric pressure: measured within 1 km of the engine test location and corrected as necessary to the test stand altitude to an accuracy of ± 100 Pa;
- d) fuel mass flow: by direct measurement to an accuracy of ± 2 per cent;
- e) fuel H/C ratio: defined as n/m , where C_mH_n is the equivalent hydrocarbon representation of the fuel used in the test and evaluated by reference to the engine fuel type analysis;
- f) engine parameters:
 - 1) thrust: by direct measurement to an accuracy of ± 1 per cent at take-off power and ± 5 per cent at the minimum thrust used in the certification test, with linear variation between these points;
 - 2) rotation speed(s): by direct measurement to an accuracy of at least ± 0.5 per cent;
 - 3) gas generator airflow: determined to an accuracy of ± 2 per cent by reference to engine performance calibration.

The parameters a), b), d) and f) shall be determined at each engine emissions test setting, while c) shall be determined at intervals of not less than 1 hour over a period encompassing that of the emissions tests.

APPENDIX 6. COMPLIANCE PROCEDURE FOR GASEOUS EMISSIONS, SMOKE AND PARTICULATE MATTER EMISSIONS

1. GENERAL

The following general principles shall be followed for compliance with the regulatory levels set forth in Part III, 2.2, 2.3, 3.2, 3.3 and 4.2:

- a) the manufacturer shall be allowed to select for certification testing any number of engines, including a single engine if so desired;
- b) all the results obtained during the certification tests shall be taken into account by the certification authority;
- c) a total of at least 3 engine tests shall be conducted, so that if a single engine is presented for certification it must be tested at least 3 times;
- d) if a given engine (i) is tested several times, the arithmetic mean value (X_i) of the tests shall be considered to be the mean value for that engine (i). The certification result is then the arithmetic mean value of the values (X_i) obtained for each engine tested;
- e) the manufacturer shall provide to the certifying authority the information specified in Part III, 2.4, 3.4, 4.2 and/or 4.3 as appropriate;
- f) the engines submitted for testing shall have emissions features representative of the engine type for which certification is sought. However, at least one of the engines shall be substantially configured to the production standard of the engine type and have fully representative operating and performance characteristics. One of these engines shall be declared to be the reference standard engine. The methods for correcting to this reference standard engine from any other engines tested shall have the approval of the national certifying authority. The methods for correcting test results for ambient effects shall be those outlined in section 7 of Appendix 3, section 7 of Appendix 5 or section 6 of Appendix 7, as applicable.

2. COMPLIANCE PROCEDURES

2.1 Gaseous emissions and Smoke Number

The certifying authority shall award a certificate of compliance if the mean of the values measured and corrected (to the reference standard engine and reference atmospheric conditions) for all the engines tested, when converted to a characteristic level using the appropriate factor which is determined by the number of engines tested (i) as shown in Table A6-1, does not exceed the regulatory level.

Note.— The characteristic level of the Smoke Number or gaseous emissions is the mean of the values of all the engines tested, and, for gaseous emissions only, appropriately corrected to the reference standard engine and reference atmospheric conditions, divided by the coefficient corresponding to the number of engines tested, as shown in Table A6-1.

Table A6-1. Coefficients to determine characteristic levels

Number of engines tested (<i>i</i>)	CO	HC	NOx	SN	nvPM mass concentration	nvPM LTO mass	nvPM LTO number
1	0.814 7	0.649 3	0.862 7	0.776 9	0.776 9	0.719 4	0.719 4
2	0.877 7	0.768 5	0.909 4	0.852 7	0.852 7	0.814 8	0.814 8
3	0.924 6	0.857 2	0.944 1	0.909 1	0.909 1	0.885 8	0.885 8
4	0.934 7	0.876 4	0.951 6	0.921 3	0.921 3	0.901 1	0.901 1
5	0.941 6	0.889 4	0.956 7	0.929 6	0.929 6	0.911 6	0.911 6
6	0.946 7	0.899 0	0.960 5	0.935 8	0.935 8	0.919 3	0.919 3
7	0.950 6	0.906 5	0.963 4	0.940 5	0.940 5	0.925 2	0.925 2
8	0.953 8	0.912 6	0.965 8	0.944 4	0.944 4	0.930 1	0.930 1
9	0.956 5	0.917 6	0.967 7	0.947 6	0.947 6	0.934 1	0.934 1
10	0.958 7	0.921 8	0.969 4	0.950 2	0.950 2	0.937 5	0.937 5
more than 10	$1 - \frac{0.130\ 59}{\sqrt{i}}$	$1 - \frac{0.247\ 24}{\sqrt{i}}$	$1 - \frac{0.096\ 78}{\sqrt{i}}$	$1 - \frac{0.157\ 36}{\sqrt{i}}$	$1 - \frac{0.157\ 36}{\sqrt{i}}$	$1 - \frac{0.197\ 78}{\sqrt{i}}$	$1 - \frac{0.197\ 78}{\sqrt{i}}$

2.2 Particulate matter emissions

2.2.1 The certifying authority shall award a certificate of compliance if the mean of the values of the maximum nvPM mass concentration measured and corrected for thermophoretic losses in the Collection Part of the sampling system for all the engines tested, when converted to a characteristic level using the appropriate factor which is determined by the number of engines tested (*i*) as shown in Table A6-1, does not exceed the regulatory level.

Note.— The characteristic level of the maximum nvPM mass concentration is the mean of the maximum values of all the engines tested, and appropriately corrected for the thermophoretic losses in the Collection Part of the sampling system, divided by the coefficient corresponding to the number of engines tested, as shown in Table A6-1.

2.2.2 The certifying authority shall award a certificate of compliance if the mean of the values of the nvPM mass and the mean of the values of the nvPM number emissions measured and corrected for thermophoretic losses in the Collection Part of the sampling system and for fuel composition for all the engines tested, when converted to a characteristic level using the appropriate factor which is determined by the number of engines tested (*i*), as shown in Table A6-1, does not exceed the regulatory level.

Note.— The characteristic level of the nvPM mass and nvPM number emissions is the mean of the values of all the engines tested, and appropriately corrected for the thermophoretic losses in the Collection Part of the sampling system and for fuel composition, divided by the coefficient corresponding to the number of engines tested, as shown in Table A6-1.

2.3 Characteristic level

The coefficients needed to determine the characteristic levels of engine emissions are given in Table A6-1.

3. PROCEDURE IN THE CASE OF FAILURE

Note.— When a certification test fails, it does not necessarily mean that the engine type does not comply with the requirements, but it may mean that the confidence given to the certifying authority in compliance is not sufficiently high, i.e. less than 90 per cent. Consequently, the manufacturer should be allowed to present additional evidence of engine type compliance.

3.1 If an engine type fails a certification test, the certifying authority shall permit the manufacturer, if he/she so wishes, to conduct additional tests on the certification engines. If the total results available still show that the engine type fails the certification requirements, the manufacturer shall be allowed to test as many additional engines as desired. The resulting test results shall then be considered with all previous data.

3.2 If the result is still failure, the manufacturer shall be allowed to select one or more engines for modification. The results of the tests already made on the selected engine(s) while unmodified shall be inspected, and further testing shall be done so that at least three tests are available. The mean of these tests shall be determined for each engine and described as the “unmodified mean”.

3.3 The engine(s) may then be modified, and at least three tests shall be conducted on the modified engine(s), the mean of which shall be described as the “modified mean” in each case. This “modified mean” shall be compared to the “unmodified mean” to give a proportional improvement which shall then be applied to the previous certification test result to determine if compliance has been achieved. It shall be determined before testing of any modified engine is begun that the modification(s) comply with the appropriate airworthiness requirements.

3.4 This procedure shall be repeated until compliance has been demonstrated or the engine type application is withdrawn.

APPENDIX 7. INSTRUMENTATION AND MEASUREMENT TECHNIQUES FOR NON-VOLATILE PARTICULATE MATTER EMISSIONS

1. INTRODUCTION

Note.— The procedures in this appendix provide guidelines for the acquisition of representative turbine engine non-volatile particulate matter (nvPM) exhaust samples, and their transport to, and analysis by, the nvPM sampling and measurement system. The procedures do not apply to engines employing afterburning.

Any equivalent procedures to those contained in this appendix shall only be allowed after prior application to and approval by the certificating authority.

2. DEFINITIONS, ACRONYMS AND SYMBOLS

2.1 Definitions

Where the following expressions are used in this appendix, they have the meanings ascribed to them below:

Accuracy. The closeness with which a measurement approaches the true value established independently.

Aerodynamic diameter of a particle. The diameter of an equivalent sphere of unit density with the same terminal settling velocity as the particle in question, also referred to as “classical aerodynamic diameter”.

Calibration gas. A high accuracy reference gas to be used for alignment, adjustment and periodic checks of instruments.

Catalytic stripper. A catalytic device that removes volatile species through oxidation.

Competent laboratory. A testing and calibration laboratory which establishes, implements and maintains a quality system appropriate to the scope of its activities, in compliance with ISO/IEC 17025:2005, as amended from time to time, or equivalent standard and for which the programme for calibration of equipment is designed and operated so as to ensure that calibrations and measurements made by the laboratory are traceable to the International System of Units (SI). Formal accreditation of the laboratory to ISO/IEC 17025:2005 is not required.

Cyclone separator. Separation of particles larger than a prescribed aerodynamic diameter via rotational and gravitational means. The specified cut-point aerodynamic diameter is associated with the percent of particles of a particular size that penetrate through the cyclone separator.

Electrical mobility diameter of a particle. The diameter of a sphere that moves with exactly the same mobility in an electrical field as the particle in question.

Elemental carbon (EC). Light absorbing carbon that is not removed from a filter sample heated to 870°C in an inert atmosphere during thermal optical transmittance (TOT) analysis, excluding char.

Gas concentration. The volume fraction of the component of interest in the gas mixture .

Non-volatile particulate matter (nvPM). Emitted particles that exist at a gas turbine engine exhaust nozzle exit plane that do not volatilize when heated to a temperature of 350°C.

Organic carbon (OC). Carbon volatilized in Helium while heating a quartz fibre filter sample to 870°C during thermal optical transmittance (TOT) analysis. Includes char formed during pyrolysis of some materials.

Particle loss. The loss of particles during transport through a sampling system. This loss is due to various deposition mechanisms, some of which are size dependent.

Particle mass concentration. The mass of particles per unit volume of sample.

Particle mass emission index. The mass of particles emitted per unit of fuel mass used.

Particle number concentration. The number of particles per unit volume of sample.

Particle number emission index. The number of particles emitted per unit of fuel mass used.

Particle size distribution. A list of values or a mathematical function that represents particle number concentration according to size.

Parts per million (ppm). The unit volume gas concentration of a gas per million unit volume of the gas mixture of which it is part.

Penetration fraction. The ratio of particle concentration downstream and upstream of a sampling system element.

Quality system. A management system in which the competent laboratory documents its policies, systems, programmes, procedures and instructions to the extent necessary to assure the quality of the test and/or calibration results.

Repeatability. The closeness with which a measurement upon a given invariant sample can be reproduced in short-term repetitions of the measurement with no intervening instrument adjustment.

Resolution. The smallest change in a measurement which can be detected.

Response. The change in instrument output signal that occurs with change in sample concentration.

Rise time. The time required for the output signal to pass from 10 per cent to 90 per cent of the final change in the output signal when a reference material is abruptly applied to the automatic measuring system initially in the basic state. (This term is only applicable for an online analyser.)

Stability. The closeness with which repeated measurements upon a given invariant sample can be maintained over a given period of time.

2.2 Acronyms

CPC	Condensation particle counter
FS	Full scale range of the analyser
GL	Gas line

HEPA	High efficiency particle air filter, class H13, which removes at least 99.97 per cent of Dioctyl Phthalate particles (0.3 µm in diameter)
ID	Internal diameter
ISA	International Standard Atmosphere (ISO 2533:1975)
LOD	Limit of detection
NMI	National metrology institute
nvPM	Non-volatile particulate matter (<i>see</i> definition)
nvPMmi	Non-volatile particulate matter mass instrument
nvPMni	Non-volatile particulate matter number instrument
PTFE	Polytetrafluoroethylene
slpm	Standard litres per minute (litres per minute at STP)
STP	Instrument condition at standard temperature 0°C and pressure 101.325 kPa
TOT	Thermal optical transmittance
VPR	Volatile particle remover
VRE	Volatile removal efficiency

2.3 Symbols

[CO]	Mean gas concentration of CO in exhaust sample, vol/vol, wet
[CO ₂]	Mean gas concentration of CO ₂ in undiluted exhaust sample, vol/vol, wet
[CO ₂] _b	Gas concentration of CO ₂ in dry air, by volume = 0.000 3
[CO ₂] _{di1}	Mean gas concentration of CO ₂ vol/vol after the first dilution stage, wet
[CO ₂] _{di2}	Mean gas concentration of CO ₂ vol/vol after the second dilution stage, wet
[CO ₂] _s	Mean gas concentration of CO ₂ vol/vol in undiluted exhaust as sampled, wet, semi-dry or dry
DF	Dilution factor = (sample concentration before dilution)/(sample concentration after dilution)
	$\frac{\text{Volume of undiluted sample}}{\text{Volume of diluted sample}}$
DF ₁	First stage dilution factor = $\frac{[\text{CO}_2]}{[\text{CO}_2]_{\text{di1}}}$

DF _{1,S}	First stage dilution factor calculated using directly sampled [CO ₂] _S and [CO ₂] _{dil}
DF ₂	Second stage (VPR) dilution factor as per calibration by a competent laboratory
D _m	nvPM electrical mobility diameter, μm
D _{xy, at z nm}	Aerodynamic diameter at which <i>xy</i> per cent (detection efficiency) of <i>z</i> size particles are detected
EI _{mass}	nvPM mass emission index corrected for thermophoretic losses and for fuel composition, in milligrams/kg fuel
EI _{num}	nvPM number emission index corrected for thermophoretic losses and for fuel composition, in number/kg fuel
F	Thrust for the given operating mode
H	Fuel hydrogen content (mass percentage)
[HC]	Mean gas concentration of hydrocarbons in exhaust sample, vol/vol, wet, expressed as carbon
η _{VPR(D_m)}	Particle penetration fraction of VPR for particles of D _m
k _{fuel_M}	Fuel composition correction factor for nvPM mass emissions index
k _{fuel_N}	Fuel composition correction factor for nvPM number emissions index
k _{thermo}	Collection Part thermophoretic loss correction factor
[NO]	Mean gas concentration of NO in exhaust sample, vol/vol, wet
[NO ₂]	Mean gas concentration of NO ₂ in exhaust sample, vol/vol, wet
[NOx]	Mean gas concentration of NO and NO ₂ in exhaust sample, vol/vol, wet = [NO]+[NO ₂]
M _C	Atomic mass of carbon = 12.011
M _H	Atomic mass of hydrogen = 1.008
m	Number of C atoms in characteristic fuel molecule
n	Number of H atoms in characteristic fuel molecule
nvPM _{mass}	nvPM mass concentration at instrument STP condition, corrected for dilution and thermophoretic losses in the collection section of the sampling system, μg/m ³
nvPM _{mass_STP}	Diluted nvPM mass concentration at instrument STP condition, μg/m ³
nvPM _{num_STP}	Diluted nvPM number concentration at instrument STP condition, number/cm ³
T _{line}	Sample line wall temperature
T ₁	Diluter 1 inlet wall temperature °C
T _{EGT}	Engine measured or performance-derived engine exhaust nozzle exit plane gas temperature °C

t_{90}	90 per cent response time (time between change in inlet concentration and the detector reaching 90 per cent of its final signal)
α	Atomic hydrogen-carbon ratio of the fuel = n/m , where C_mH_n is the equivalent hydrocarbon representation of the fuel used in the test and evaluated by reference to the engine fuel type analysis.

3. DATA REQUIRED

3.1 nvPM emissions

3.1.1 In order to calculate the nvPM mass and number emissions, the following concentrations shall be determined:

- a) nvPM mass: $nvPM_{mass_STP}$;
- b) nvPM number: $nvPM_{num_STP}$;
- c) carbon dioxide (CO₂): [CO₂] and [CO₂]_{dil};
- d) carbon monoxide (CO): [CO];
- e) hydrocarbons (HC): [HC]; and
- f) oxides of Nitrogen (NO_x): [NO_x], [NO], [NO₂].

Note.— Guidance material on the required data is provided in the Environmental Technical Manual (Doc 9501), Volume II — Procedures for the Emissions Certification of Aircraft Engines.

3.1.2 For system operability check purposes, the concentration of the following emission shall be determined:

carbon dioxide (CO₂): [CO₂]_S

3.2 Other information

In order to normalize the emissions measurement data and to define the engine test characteristics, additional information listed in Attachment F to Appendix 3 and Attachment D to this appendix shall be provided.

4. GENERAL ARRANGEMENT OF THE nvPM SAMPLING AND MEASUREMENT SYSTEM

4.1 nvPM sampling and measurement system

4.1.1 The nvPM sampling and measurement system shall consist of three parts, divided into five sections:

- a) collection part (Section 1);
- b) transfer part (Sections 2, 3 and 4); and
- c) measurement part (Section 5).

Note 1.— An overview description of the nvPM sampling and measurement system is provided in Figure A7-1 and Table A7-1.

Note 2.— More detailed requirements and recommendations for each section of the system are provided in Attachments A, B, C and E to this appendix.

4.1.2 Sections 1 to 4 shall meet the following requirements:

- a) The sample lines shall be as straight-through as possible.
- b) The total sample line length from probe tip to measurement instrument inlet shall not exceed 35 m. This total length is not equal to the sum of the individual sampling sections maximum allowable lengths. Detailed length requirements are provided in Attachment A to this appendix and shown in Figure A7-1.

4.1.3 Recommendation.— The following is recommended for Sections 1 to 4:

- a) The number of fittings should be minimized and should be manufactured from stainless steel material with a smooth bore.
- b) The number of bulkhead union fittings should be minimized and should be thermally insulated to minimize thermal gradients.

Note.— Guidance material is provided in the Environmental Technical Manual (Doc 9501), Volume II — Procedures for the Emissions Certification of Aircraft Engines.

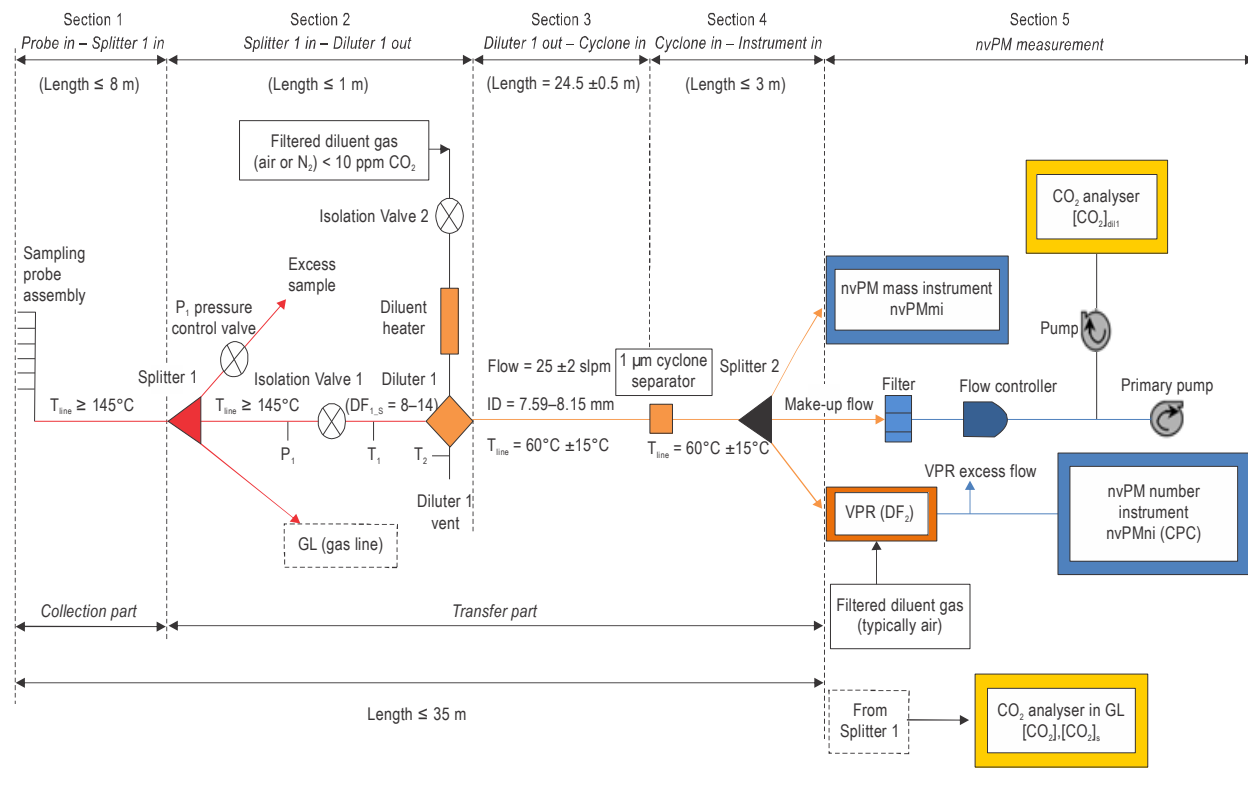

Figure A7-1. Overview schematic of an nvPM sampling and measurement system

Table A7-1. nvPM sampling and measurement system terminology overview

<i>Terminology</i>		<i>Description</i>
Section 1	Sampling probe assembly	Single or multi-point rake hardware used to obtain representative sample from aircraft engine exhaust.
	Connection line	Length of tubing to transport sample from probe to Splitter 1 inlet.
Section 2	Splitter 1	Flow splitter assembly to allow controlled separation of samples to both particle and gas sampling systems. Also provides a flow path (excess sample) to relieve and control sample line pressure.
	P ₁ pressure control valve	Valve used to control pressure at Diluter 1 inlet.
	P ₁	Diluter 1 inlet pressure; regulated by the pressure control valve when P ₁ is above ambient.
	T ₁	Sample tube temperature at Diluter 1 inlet needed for thermophoretic particle loss calculation in Sections 1 and 2.
	Isolation valve 1	Allows isolation of the particle system from the GL sample and allows leakage checks of GL (including probe) and cleanliness check of transfer part.
	Isolation valve 2	Diluent shut-off valve for Diluter 1.
	Diluter 1	Ejector-type diluter, which provides a near ambient pressure to the inlet of Section 3. Dilutes the nvPM sample early in the transfer Part (first stage dilution, DF ₁) to minimize particle coagulation and reduces sample temperature to minimize thermophoretic losses.
	Filtered diluent gas	Compressed gas (air or nitrogen) for Diluter 1.
	Diluent heater	Heats the diluent prior to entering the Diluter 1. Heater temperature controlled by Diluter 1 vent temperature (T ₂).
	Diluter 1 vent	Allows venting of excess diluted sample to atmosphere to maintain near-ambient pressure at Diluter 1 exhaust and prevent over pressuring the transfer part.
T ₂	Temperature in vent flow to control Diluter 1 outlet temperature.	
GL	Gas line. Heated section to transport the exhaust sample for gaseous emissions measurement.	
Section 3	Heated sample line	Standardized sampling section. Allows measurements at a safe distance from the engine.
Section 4	1 µm cyclone separator	Removes large particles not generated by combustion and helps to prevent instrumentation blockage.
	Splitter 2	Flow splitter assembly to provide sample flow paths for nvPM mass and number concentration measurement and a third flow path to ensure that the total system flow rate in Section 3 is maintained.
Section 5	Filter	Particle filter to prevent blockage and damage to the flow controller.
	Flow controller	Maintains constant flow rate in Section 3 by controlling make-up flow.
	Primary pump	Provides suction for the make-up flow.
	CO ₂ analyser	Measurement of [CO ₂] _{dil1} in the diluted sample.
	nvPMmi	nvPM mass instrument
	VPR (DF ₂)	Device that removes volatile species and dilutes further the sample (second stage dilution, DF ₂) prior to the nvPMni.
	Filtered diluent gas	Diluent gas (air or nitrogen) for VPR.
	nvPMni (CPC)	nvPM number instrument that is a condensation particle counter.

4.1.4 Sections 2 to 4 shall meet the following requirements:

- a) Any necessary sampling line bends shall have radii greater than 10 times the ID of the line.
- b) There shall not be forward facing step-shoulders greater than 15 per cent of the ID.
- c) Changes in sampling line ID greater than 15 per cent shall only occur at a splitter flow path interface.
- d) Differences in ID of less than or equal to 15 per cent shall be considered as no change.

4.1.5 **Recommendation.**— *For Sections 2 to 4 the sampling line should be actively heated across a fitting. If not practical, the sample line should be heated as close as possible to the next heated element and thermally insulated across the fitting.*

4.2 Collection Part

4.2.1 Section 1 is comprised of the probe/rake hardware and the connection line. It shall meet the following requirements:

- a) The sampling probe material shall be stainless steel or any other non-reactive high temperature material.
- b) If a sampling probe with multiple sample orifices is used:
 - 1) all sampling orifices shall be of equal diameter; and
 - 2) the sampling probe design shall be such that at least 80 per cent of the pressure drop through the sampling probe assembly is taken at the orifices.
- c) The number of locations sampled shall not be less than 12.
- d) The sampling plane shall be as close to the engine exhaust nozzle exit plane as permitted by considerations of engine performance but in any case shall be within 0.5 nozzle diameter of the exit plane.
- e) The applicant shall provide evidence to the certificating authority, by means of detailed traverses, that the proposed probe design and position does provide a representative sample for each prescribed thrust setting.

Note.— *Guidance material on procedures for representative measurements is provided in the Environmental Technical Manual (Doc 9501), Volume II — Procedures for the Emissions Certification of Aircraft Engines.*

4.3 Transfer part

4.3.1 At the inlet to Section 2, the Splitter 1 assembly shall split the sample into the transfer part line, the GL for the measurement of undiluted CO₂, CO, HC and NO_x, and the excess sample line.

Note.— *This arrangement also allows the GL to be used to measure Smoke Number, if required, as specified in Appendix 2.*

4.3.2 The transfer part line shall be arranged such that the nvPM sample:

- a) passes through Diluter 1, an ejector-type diluter, which draws, dilutes and cools the sample;
- b) passes through Section 3; and
- c) passes through a cyclone separator and Splitter 2 in Section 4 before entering the measurement part in Section 5.

4.4 Measurement part

4.4.1 nvPM mass measurement

4.4.1.1 The nvPMmi shall meet the requirements in Attachment B to this appendix.

4.4.1.2 Each make and model of the nvPMmi shall receive a certificate from the instrument manufacturer or from another competent testing and calibration laboratory confirming that the make and model of the nvPMmi meets the performance specifications listed in Table A7-3 of Attachment B to this appendix.

4.4.2 nvPM number measurement

4.4.2.1 The nvPM number concentration shall be determined using a system consisting of a volatile particle remover (VPR) and a condensation particle counter (CPC) (nvPMni) in series. The VPR includes a dilution system (DF₂) and a device for the removal of volatile species.

4.4.2.2 Each make and model of the VPR and CPC shall receive a certificate from the instrument manufacturer or from another competent testing and calibration laboratory confirming that the make and model of each device meets the performance specifications listed in Attachment C to this appendix.

4.4.3 Make-up flow path

- a) The make-up flow path shall be used to maintain a constant sample flow rate through Section 3 and provide a diluted sample CO₂ concentration measurement.
- b) The make-up flow path shall contain a pump, flow controller and CO₂ analyser.
- c) **Recommendation.**—*A particle filter should be placed upstream of the flow controller to prevent damage to components.*

5. GENERAL TEST PROCEDURE

5.1 Calibration and maintenance

5.1.1 All instruments shall be maintained conforming to the manufacturer's guidelines.

5.1.2 The nvPM sampling and measurement system

Calibration and maintenance of the nvPM sampling and measurement system shall be performed as follows at least on an annual basis or as recommended by the manufacturer:

- a) The cyclone separator collection reservoir shall be emptied and cleaned.
- b) The Diluter 1 orifice nozzle shall be cleaned.

- c) The make-up flow controller and inlet flow rates for nvPMmi, nvPMni and VPR shall be calibrated by a NMI-traceable flow meter.
- d) **Recommendation.**— *All calibrated flow rates should be within 5 per cent FS.*
- e) Pressure transducers shall be calibrated by a NMI-traceable pressure transducer.
- f) **Recommendation.**— *All calibrated pressure measurements should be within 2 per cent FS.*

5.1.3 nvPMmi

- a) The nvPMmi shall be annually calibrated by a competent laboratory to meet the calibration requirements prescribed in Attachment B to this appendix.
- b) The nvPMmi shall demonstrate compliance to performance specifications listed in Table A7-3 of Attachment B to this appendix after hardware or software changes to the nvPMmi which affect data acquisition and processing.

Note.— *Guidance material is provided in the Environmental Technical Manual (Doc 9501), Volume II — Procedures for the Emissions Certification of Aircraft Engines.*

5.1.4 VPR

- a) The VPR shall be annually calibrated by a competent laboratory to meet the requirements prescribed in Attachment C to this appendix.
- b) If the VPR contains a catalytic stripper, its replacement interval shall meet the manufacturer guidelines.

5.1.5 nvPMni (CPC)

- a) The nvPMni shall be annually calibrated by a competent laboratory to meet the calibration requirements prescribed in Attachment C to this appendix.
- b) The nvPMni working fluid shall be n-butanol and shall be replaced following the manufacturer guidelines.
- c) The nvPMni shall demonstrate compliance to performance specifications listed in Attachment C to this appendix after any hardware or software changes to the nvPMni which affect data acquisition and processing.

Note.— *Guidance material is provided in the Environmental Technical Manual (Doc 9501), Volume II — Procedures for the Emissions Certification of Aircraft Engines.*

5.1.6 Gas analysers

- a) Calibration of the CO₂, CO, HC and NO_x analysers shall be in accordance with the procedures of Appendix 3.
- b) The CO₂ impurity of the zero calibration gas for the CO₂ analyser downstream of Diluter 1 shall be less than 10 ppm.

Note.— *The CO₂ impurity specification for the CO₂ analyser downstream of Diluter 1 is different from Attachment D to Appendix 3.*

- c) **Recommendation.**— *The diluent for Diluter 1 should be the same as the zero calibration gas used for the CO₂ analyser.*

5.2 Engine operation

5.2.1 The engine shall be operated on a static test facility which is suitable and properly equipped for high accuracy performance testing.

5.2.2 The nvPM emissions tests shall be made at the thrust settings prescribed by the certifying authority. The engine shall be stabilized at each setting.

5.3 Carbon balance

Each test shall include a check that the air/fuel ratio as estimated from the integrated sample total carbon concentration exclusive of smoke agrees with the estimate based on engine air/fuel ratio with an accuracy of ± 15 per cent for the taxi/ground idle mode, and with an accuracy of ± 10 per cent for all other operating modes.

Note.— *Guidance material on the use of an equivalent procedure is provided in the Environmental Technical Manual (Doc 9501), Volume II — Procedures for the Emissions Certification of Aircraft Engines.*

5.4 Operation of nvPM sampling and measurement system

5.4.1 Prior to an engine test series, the following requirements shall be met:

- a) Collection part leakage and cleanliness checks shall be performed using the procedures described in Attachment E to this appendix.
- b) A VPR dilution factor (DF₂) check shall be performed as described in Attachment E.

5.4.2 The following procedure shall be adopted for gaseous measurements on the GL and downstream of Diluter 1:

- a) Apply appropriate zero calibration gas and make any necessary instrument adjustments.
- b) Apply appropriate calibration gas at a nominal 90 per cent FS concentration to span the ranges to be used, adjust and record gain settings accordingly.

5.4.3 During an engine test series, the following requirements shall be met:

- a) The nvPM measurements shall only be taken after all instruments and sample transfer lines are warmed up and stable.
- b) If any component or section of the nvPM sampling system is new, cleaned since last use or used previously for a purpose other than sampling engine exhaust, then the nvPM sampling system shall sample aircraft engine exhaust for a minimum of 30 minutes at any engine power condition prior to obtaining nvPM measurements.

Note.— *Removal of soot blockage in the Diluter 1 orifice does not constitute a cleaning process as defined in b).*

- c) The nvPMmi manufacturer recommended operability checks shall be performed.

- d) For nvPM number measurements, the following requirements shall be met:
- 1) The VPR heated stage is at 350°C ±15°C.
 - 2) If a catalytic stripper is used in the VPR, the diluent shall contain at least 10 per cent of O₂.
 - 3) The nvPMni working fluid is at the level required by the manufacturer.
 - 4) The nvPMni saturator and the condenser have reached correct operating temperatures.
- e) The nvPMni manufacturer recommended operability checks shall be performed.
- f) A transfer part cleanliness check shall be performed at the beginning and end of an engine test using the procedures described in Attachment E to this appendix.

Note.— The transfer part cleanliness check also serves as an operational nvPM instrumentation zero check.

- g) Ambient nvPM measurements shall be performed at the beginning and end of an engine test using the procedures described in Attachment E to this appendix.

Note.— The ambient measurement also serves as an operational nvPMni response check.

- h) Gaseous analyser zero and calibration points shall be rechecked at the end of the test and also at intervals not greater than 1 hour during tests. If either has changed by more than ±2 per cent of FS range, the test shall be repeated after restoration of the instrument to within its specification.

5.4.3.1 **Recommendation.**— *Section 1 back-purging should occur during engine start-up and shutdown.*

5.4.4 During engine nvPM measurements, the following requirements shall be met:

- a) If P₁ is at sub-atmospheric pressure, the P₁ pressure control valve shall be closed; and if installed, the optional shut-off valve shall be closed.
- b) Both the GL CO₂ concentration and the CO₂ concentration downstream of Diluter 1, [CO₂]_{dil1}, shall be continuously measured and used for validating and controlling DF₁ in real time (DF_{1_s}) to within the range 8 to 14. DF_{1_s} is defined as:

$$DF_{1_s} = \frac{[CO_2]}{[CO_2]_{dil1}}$$

Note.— The calculation of DF_{1_s} does not require the CO₂ concentration on a wet basis.

- c) The sample flow rate of 25 slpm ±2 slpm in Section 3 shall be monitored by summation of the make-up flow and the inlet flow rates of the nvPMmi and the VPR.
- d) When the engine operation and measured nvPM and [CO₂]_{dil1} concentrations are stable at the required thrust setting, a minimum of 30 seconds of data shall be averaged and recorded.
- e) If the nvPMmi lacks a sample pressure measurement, the pressure shall be measured at a location between the Splitter 2 outlet and the make-up flow inlet, and recorded.

- f) If the nvPMni lacks a sample pressure measurement, the pressure shall be measured at a location between the VPR outlet and nvPMni inlet, and recorded.

6. CALCULATIONS

6.1 nvPM mass concentration and nvPM mass and number emission indices equations

This procedure is used to calculate nvPM mass concentration and nvPM mass and number emission indices (EIs) from aircraft gas turbine engines burning hydrocarbon fuel in air. All equations utilize the nvPM mass concentration and nvPM number concentration at instrument STP conditions. If this is not the case, the user shall follow recommended procedures per the instrument manufacturer to correct the reported concentrations to STP conditions for the instrument.

6.1.1 nvPM mass concentration

The nvPM mass concentration ($\text{nvPM}_{\text{mass}}$) represents the mass of particles per unit volume of engine exhaust sample corrected for the first stage dilution factor (DF_1) and the Collection Part thermophoretic particle losses. It is calculated using the following equation:

$$\text{nvPM}_{\text{mass}} = \text{DF}_1 \times \text{nvPM}_{\text{mass_STP}} \times k_{\text{thermo}}$$

6.1.2 nvPM mass and number emission indices

The nvPM mass and nvPM number emission indices (EI_{mass} and EI_{num}) represent the mass (in milligrams) and number of engine exhaust particles per mass of fuel burned (in kilograms) corrected for their respective dilution factors, the Collection Part thermophoretic particle losses and their respective fuel composition correction factors. They are calculated using the following equations:

$$\text{EI}_{\text{mass}} = \frac{22.4 \times \text{nvPM}_{\text{mass_STP}} \times 10^{-3}}{\left([\text{CO}_2]_{\text{dil1}} + \frac{1}{\text{DF}_1} ([\text{CO}] - [\text{CO}_2]_{\text{b}} + [\text{HC}]) \right) (M_{\text{C}} + \alpha M_{\text{H}})} \times k_{\text{thermo}} \times k_{\text{fuel_M}}$$

$$\text{EI}_{\text{num}} = \frac{22.4 \times \text{DF}_2 \times \text{nvPM}_{\text{num_STP}} \times 10^6}{\left([\text{CO}_2]_{\text{dil1}} + \frac{1}{\text{DF}_1} ([\text{CO}] - [\text{CO}_2]_{\text{b}} + [\text{HC}]) \right) (M_{\text{C}} + \alpha M_{\text{H}})} \times k_{\text{thermo}} \times k_{\text{fuel_N}}$$

$[\text{CO}_2]$, $[\text{CO}]$ and $[\text{HC}]$ shall be calculated as shown in Attachment E to Appendix 3.

Note 1.— The constant 22.4 used in the EI equations above is the volume of one mole of air in litres at STP conditions rounded to one decimal place.

Note 2.— Guidance material on the use of an equivalent procedure is provided in the Environmental Technical Manual (Doc 9501), Volume II — Procedures for the Emissions Certification of Aircraft Engines.

6.2 Correction factors for nvPM emissions

6.2.1 Correction for nvPM thermophoretic losses in the Collection Part

The correction for nvPM thermophoretic losses in the collection part shall be determined using:

$$k_{\text{thermo}} = \left(\frac{T_1 + 273.15}{T_{\text{EGT}} + 273.15} \right)^{-0.38}$$

If $T_{\text{EGT}} < T_1$, then $k_{\text{thermo}} = 1$

Note.— *Guidance material is provided in the Environmental Technical Manual (Doc 9501), Volume II — Procedures for the Emissions Certification of Aircraft Engines.*

6.2.2 Correction for fuel composition

The correction for fuel composition shall be determined using:

$$k_{\text{fuel}_M} = \exp \left\{ \left(1.08 \frac{F}{F_{00}} - 1.31 \right) (13.8 - H) \right\}$$

$$k_{\text{fuel}_N} = \exp \left\{ \left(0.99 \frac{F}{F_{00}} - 1.05 \right) (13.8 - H) \right\}$$

6.3 Control parameter functions

The EI shall be normalized to the combustor inlet temperature of the reference standard engine at ISA sea level conditions.

6.3.1 Definitions

Reference standard engine: An engine substantially configured to the production standard of the engine type, with fully representative operating and performance characteristics

F_{00} Rated thrust (see Part I, Chapter 1, Definitions)

F_n Thrust at operating mode n for reported nvPM emissions (kN)

W_f Fuel mass flow rate of the reference standard engine under ISA sea level conditions (kg/s)

W_{fn} Fuel mass flow rate of the reference standard engine under ISA sea level conditions at LTO operating mode n

T_B Combustor inlet temperature

6.3.2 The nvPM mass and number EIs shall be obtained for each LTO operating mode at T_B of the reference standard engine. A minimum of three test points shall be required to define the idle mode. For each LTO operating mode, the corresponding fuel flow under ISA conditions shall be obtained. The following relationships shall be determined under ISA reference conditions for nvPM mass and number EIs:

- a) between EI and T_B ; and
- b) between W_f and T_B ; and
- c) between F_n and T_B .

Note 1.— These relationships are illustrated, for example, by Figure A7-2 a), b) and c).

Note 2.— The relationships b) and c) may be established directly from engine test data, or may be derived from a validated engine performance model.

6.4 Calculation procedure

The estimation of EI (referenced to T_B) for nvPM mass and number emissions at the reported operating modes shall comply with the following general procedure:

- a) Determine the combustor inlet temperature (T_B) (Figure A7-2 c)) at the values of F_n corresponding to the reported operating modes, n under reference atmospheric conditions.
- b) From the EI/ T_B characteristic (Figure A7-2 a)), determine the EI _{n} value corresponding to T_B .
- c) From the W_f / T_B characteristic (Figure A7-2 b)), determine the W_{f_n} value corresponding to T_B .

Note.— While the methodology described above is the recommended method, the certifying authority may accept equivalent mathematical procedures which utilize mathematical expressions representing the curves illustrated if the expressions have been derived using an accepted curve fitting technique.

6.5 Exceptions to the proposed procedures

Note.— In those cases where the configuration of the engine or other extenuating conditions exist which would prohibit the use of this procedure, the certifying authority, after receiving satisfactory technical evidence of equivalent results obtained by an alternative procedure, may approve an alternative procedure.

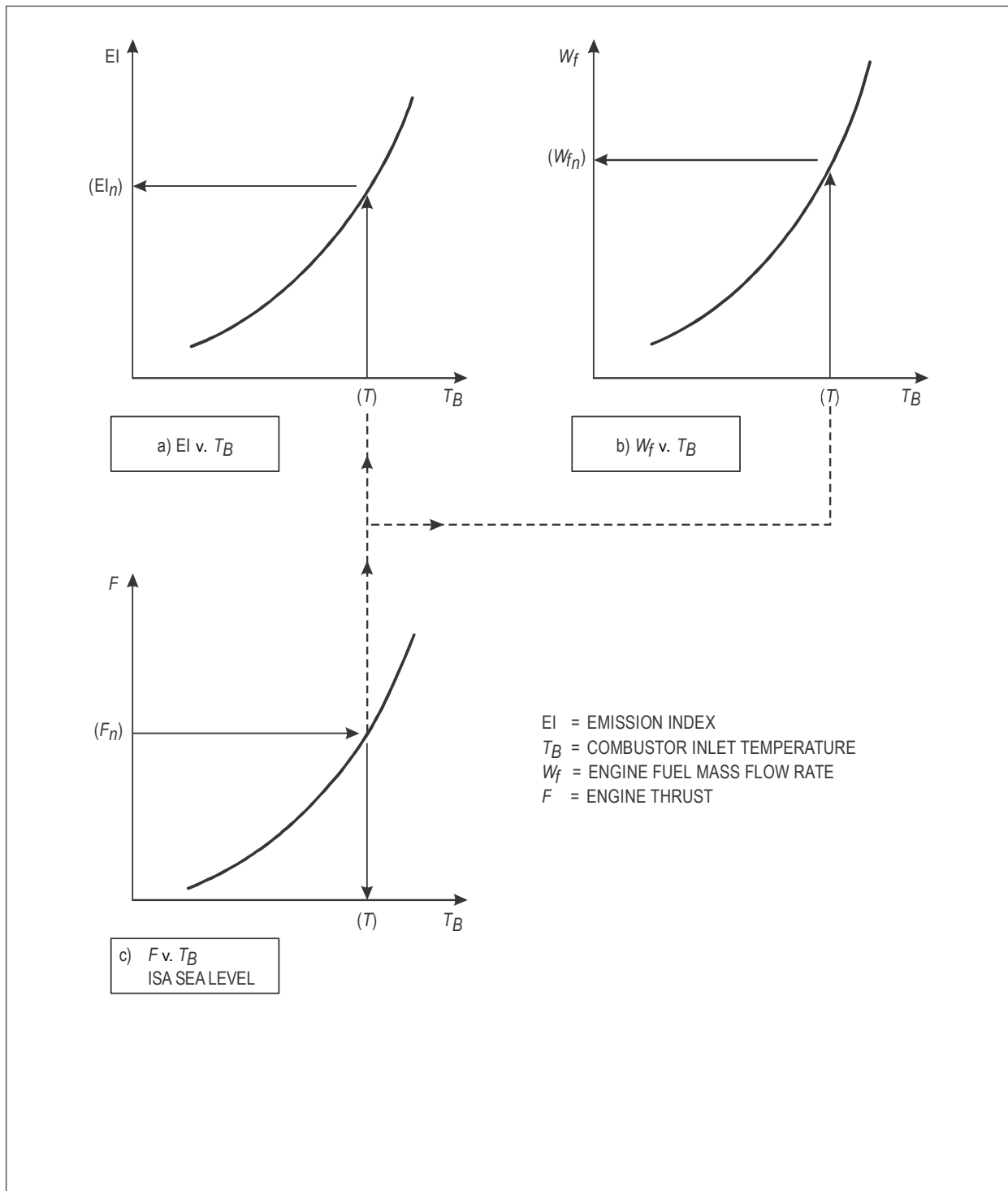

Figure A7-2. Turbine engine nvPM EI as a function of several engine parameters

ATTACHMENT A TO APPENDIX 7. REQUIREMENTS AND RECOMMENDATIONS FOR nvPM SAMPLING SYSTEM

1. SECTION 1: PROBE INLET — SPLITTER 1 INLET

1.1 Section 1 shall meet the following requirements:

- a) The sample shall be transferred from the probe to Section 2 via a line of 4.0 to 8.5 mm ID, taking the shortest route practicable.
- b) The sampling line shall be maintained at a temperature greater than or equal to 145°C.
- c) The length from probe inlet to the Splitter 1 inlet shall be less than or equal to 8 m.

2. SECTION 2: SPLITTER 1 INLET — DILUTER 1 OUTLET

2.1 Section 2 shall meet the following requirements:

- a) Section 2 shall contain Splitter 1 and Diluter 1.
- b) The material of the sample line shall be such as to minimize build-up of particulate matter or static electricity.

Note.— Stainless steel or carbon-loaded electrically grounded PTFE meets these requirements.

- c) The length of Section 2 from the Splitter 1 inlet to the Diluter 1 outlet shall not exceed 1 m.
- d) Section 2 shall contain Isolation Valve 1 in order to perform the leakage check on the GL.

2.2 Splitter 1 shall meet the following requirements:

- a) Splitter 1 shall be made of stainless steel.
- b) Splitter 1 body temperature shall be maintained at greater than or equal to 145°C.
- c) Splitter 1 shall separate the engine exhaust sample into three flow paths.
- d) The split angles relative to the incoming flow shall be as acute as practical but not exceeding 35°.
- e) The nvPM sample flow path shall be as straight-through and short as practical.
- f) Splitter 1 internal geometry shall meet the following requirements:
 - 1) no forward facing step-shoulders on the inner wall;
 - 2) no change in ID from Splitter 1 outlet to Diluter 1 inlet;

- 3) GL ID = 4 to 8.5 mm; and
- 4) excess sample line internal cross sectional area greater than or equal to the total inlet area of the probe tips.

2.3 Isolation Valve 1 shall meet the following requirements:

- a) Isolation Valve 1 shall be placed between Splitter 1 outlet and Diluter 1 inlet.
- b) Isolation Valve 1 shall be full bore with no forward facing step-shoulders greater than 15 per cent of the ID.
- c) The seals of Isolation Valve 1 shall be dry and heat resistant to 175°C.

2.4 The nvPM Section 2 line wall temperature (T_1), to within 5 cm of the Diluter 1 mixing plane, shall be maintained at greater than or equal to 145°C as shown in Figure A7-3.

2.5 Diluter 1 shall meet the following requirements:

- a) Diluter 1 shall be an ejector-type diluter.
- b) The ID of Diluter 1 inlet shall be greater than or equal to 7.59 mm.
- c) The diluent flow shall be controlled as specified by the manufacturer.
- d) The real-time Diluter 1 DF shall be controlled within the range of 8 to 14.

Note 1.— The minimum DF is required to minimize nvPM coagulation, while the maximum is needed to maintain the diluted sample within the measurement range of the instruments.

Note 2.— DF_1 may be adjusted by controlling P_1 with the pressure control valve on the excess sample flow path or by adjusting the diluent gas flow.

- e) The Diluter 1 vent shall be open to ambient (equal to engine inlet pressure).
- f) The Diluter 1 body shall be heated to 60°C ±15°C as shown in Figure A7-3.
- g) The diluent shall be air or nitrogen, be HEPA filtered and contain less than 10 ppm CO₂.
- h) The diluent shall be heated to provide a diluted nvPM sample temperature of 60°C ±15°C at the Diluter 1 vent (T_2).
- i) The particle penetration of Diluter 1 shall meet the minimum requirements as shown in Table A7-2.

Table A7-2: Minimum requirements for particle penetration fractions (transmission efficiencies) of Diluter 1

Particle mobility size (diameter)	15 nm	30 nm	50 nm	100 nm
Minimum particle penetration fraction	80 per cent	90 per cent	90 per cent	90 per cent

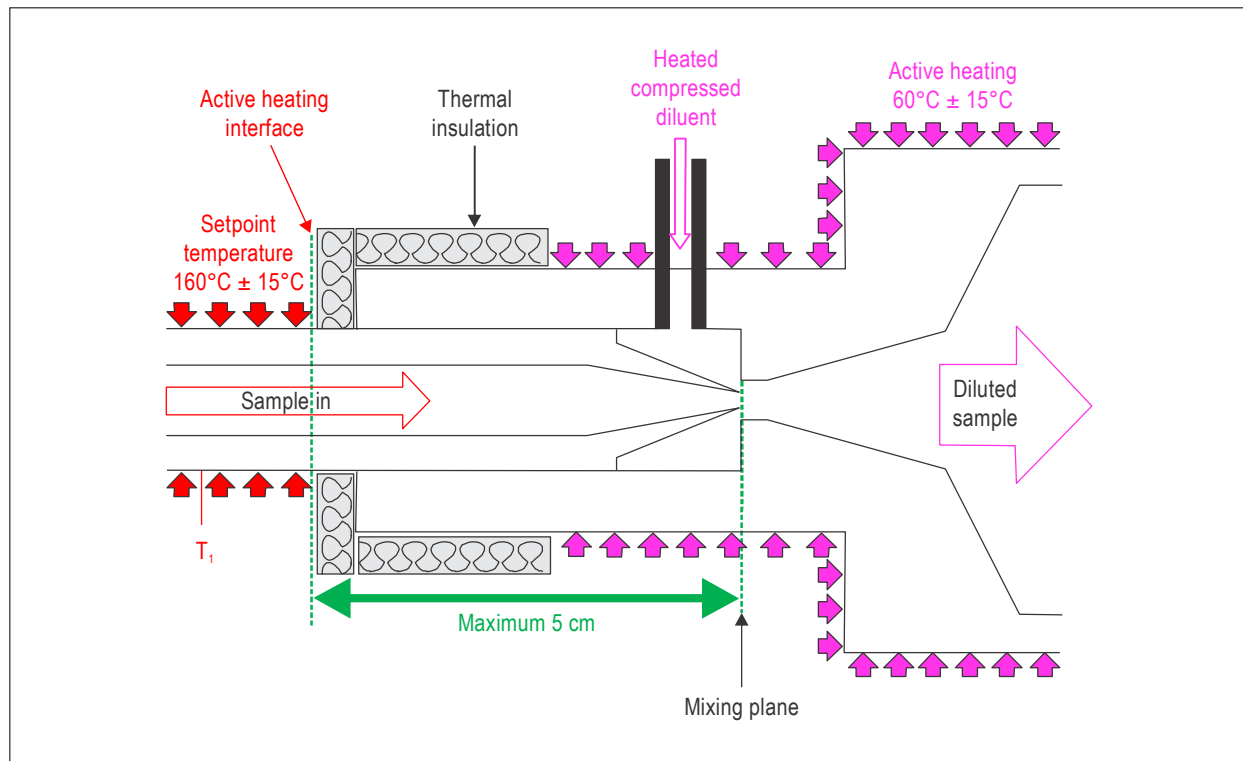

Figure A7-3. Cross section of example ejector-type Diluter 1 inlet with heating interface

2.5.1 Recommendation.— To minimize impact on the operable DF_1 range, the Diluter 1 vent line pressure drop should be kept to a minimum, as practically possible.

2.5.2 Recommendation.— A safety feature should be implemented to prevent the diluent heater from overheating when the diluent is not flowing.

2.6 Gas line

2.6.1 The GL and gaseous emissions analysers shall meet the specifications in Appendix 3 and attachments to Appendix 3.

Note.— The collection part (Section 1) of the nvPM sampling and measurement system meets the specifications in Appendix 3.

2.6.2 For nvPM EI determination, GL measurements of CO, HC and NO_x gaseous concentrations shall be performed simultaneously.

Note.— Guidance material is provided in the Environmental Technical Manual (Doc 9501), Volume II — Procedures for the Emissions Certification of Aircraft Engines.

2.6.3 For determination of $DF_{1,s}$, a GL measurement of CO₂ concentration (dry, semi-dry or wet) shall be performed simultaneously with the nvPM measurements.

2.7 Excess sample line

2.7.1 The sample line pressure at Diluter 1 inlet (P_1) shall be maintained near local ambient air pressure using a suitable pressure control valve with sufficient internal area. When fully closed, the valve shall be capable of holding a vacuum pressure of -75 kPa relative to ambient.

2.7.2 **Recommendation.**— *An optional shut-off valve, with sufficient internal area to avoid system back pressure, should be added downstream of the pressure control valve to prevent leakage at sub-atmospheric conditions inside Splitter 1.*

3. SECTION 3: DILUTER 1 OUTLET — CYCLONE SEPARATOR INLET

3.1 The sampling line shall meet the following requirements:

- a) The sampling line material shall be carbon-loaded electrically grounded PTFE.
- b) **Recommendation.**— *The sampling line should meet the anti-static specification in ISO 8031.*
- c) The sampling line ID shall be between 7.59 mm and 8.15 mm.

Note.— *Accounting for manufacturing tolerances, the sampling line ID specification corresponds to commercially available line outer diameter dimensions of 3/8 inch and 7/16 inch, both with 0.035 inch wall thickness; and 10 mm with a 1 mm wall thickness.*

- d) The line shall be of length $24.5 \text{ m} \pm 0.5 \text{ m}$, have no unnecessary fittings and consist of a maximum of three segments.
- e) The coiled sample line bend radii shall be greater 0.5 m.
- f) The sampling line temperature shall be maintained at $60^\circ\text{C} \pm 15^\circ\text{C}$ through active heating.
- g) The sample flow shall be maintained at $25 \text{ slpm} \pm 2 \text{ slpm}$.

4. SECTION 4: CYCLONE SEPARATOR INLET — INSTRUMENT INLET

4.1 Cyclone separator

The cyclone separator shall meet the following requirements:

- a) The cyclone separator material shall be stainless steel.
- b) The cyclone separator shall be heated to $60^\circ\text{C} \pm 15^\circ\text{C}$.
- c) The cyclone separator inlet and outlet IDs shall be less than a 15 per cent difference to the inlet and outlet sample line ID.
- d) The performances of the cyclone separator at a sample flow rate of 25 slpm shall meet the following specifications:
 - 1) cut-point: $D_{50} = 1.0 \mu\text{m} \pm 0.1 \mu\text{m}$;

- 2) sharpness: $(D_{16}/D_{84})^{0.5}$ less than or equal to 1.25; and
- 3) pressure drop: ΔP less than or equal to 2 kPa.

4.2 Splitter 2

Splitter 2 shall meet the following requirements:

- a) Splitter 2 body material shall be stainless steel.
- b) Splitter 2 shall be heated to $60^{\circ}\text{C} \pm 15^{\circ}\text{C}$.
- c) Splitter 2 shall separate the sample into three flow paths to deliver the diluted nvPM sample to:
 - 1) nvPMmi;
 - 2) VPR; and
 - 3) make-up flow.
- d) The split angles relative to the incoming flow shall be as acute as practical not exceeding 35° .
- e) All nvPM flow paths shall be as short as practical.
- f) The Splitter 2 geometry shall meet the following requirements:
 - 1) no forward facing shoulders on the inner wall;
 - 2) no change in ID from Splitter 2 outlet to nvPMmi inlet; and
 - 3) no change in ID from Splitter 2 outlet to VPR inlet.

4.3 Measurement system interface

The sampling lines to the nvPMmi and VPR shall meet the following requirements:

- a) The sampling line material shall be of stainless steel or carbon loaded electrically grounded PTFE.
- b) **Recommendation.**— *If the sampling line is carbon-loaded electrically grounded PTFE, it should meet the anti-static specification in ISO 8031.*
- c) The sampling line shall be heated to $60^{\circ}\text{C} \pm 15^{\circ}\text{C}$.
- d) No change in ID between the sampling line and the instrument inlets.
- e) Each total line length from cyclone separator inlet to the inlet of the nvPMmi and VPR shall be kept as short as practical and shall not exceed 3 m.

5. SECTION 5: nvPM MEASUREMENT

5.1 Make-up flow

5.1.1 The make-up flow path components shall meet the following requirements:

- a) The primary pump and flow controller to maintain a constant total sample flow rate (flow rate sum of make-up flow, nvPMmi and VPR) of 25 slpm \pm 2 slpm up to 10 kPa below ambient, through Section 3.
- b) The CO₂ analyser to measure continuously CO₂ concentration downstream of Diluter 1, [CO₂]_{dil1}, during the nvPM measurement.

Note 1.— Depending on the sampling configuration, there may be multiple flow controllers and pumps.

Note 2.— Guidance material is provided in the Environmental Technical Manual (Doc 9501), Volume II — Procedures for the Emissions Certification of Aircraft Engines.

5.1.1.1 **Recommendation.**— *Particle filters should be placed upstream of flow controllers to prevent damage to components.*

5.1.2 If the nvPMmi lacks a sample pressure measurement, the pressure shall be measured at the Splitter 2 outlet to the make-up flow path.

5.1.3 The CO₂ analyser shall meet the following requirements:

- a) The CO₂ analyser shall be located after a flow controller.
- b) The CO₂ analyser shall meet the performance specifications given in Attachment B to Appendix 3 under the headings *CO and CO₂ analysers* and *CO₂ analyser* with the exception of a).

5.1.3.1 **Recommendation.**— *The CO₂ analyser total range should be approximately ten times lower than the CO₂ analyser used on the GL.*

ATTACHMENT B TO APPENDIX 7. SPECIFICATION FOR nvPM MASS INSTRUMENT AND CALIBRATION

Note 1.— In this attachment, elemental carbon (EC) mass is being used as a surrogate for nvPM mass. Guidance is provided in the Environmental Technical Manual (Doc 9501), Volume II — Procedures for the Emissions Certification of Aircraft Engines.

Note 2.— A full descriptive text for the thermal optical transmittance (TOT) measurement reference method is provided in section 2 of this attachment. This method is commonly performed by calibration laboratories; it is not expected that the aircraft engine manufacturer would perform this method.

Note 3.— The following ISO reference is used in this attachment: International Standards Organization, Air quality — Definition and determination of performance characteristics of an automatic measuring system (ISO 9169: 2006).

1. SPECIFICATIONS

Each make and model of the nvPMmi shall receive a certificate from the instrument manufacturer or from another competent testing and calibration laboratory confirming that it:

- a) shall have a measurement range of $0 \mu\text{g}/\text{m}^3$ to $1000 \mu\text{g}/\text{m}^3$ or greater;
- b) shall have a resolution of $1 \mu\text{g}/\text{m}^3$ or better;
- c) shall be insensitive to volatile particulate matter; and

Note 1.— Volatile particulate matter is combustion exhaust material that volatilizes at temperatures less than or equal to 350°C .

Note 2.— This specification is met when the nvPMmi meets the applicability performance specification in Table A7-3.

- d) meets the performance specifications listed in Table A7-3.

Note 1.— References to ISO 9169 in Table A3-7 that are denoted by an asterisk refer to sections for which modifications are applied as described in section 4 of this attachment.

Note 2.— The performance specifications reflect the limits of the quantities that can be verified using thermal optical transmittance (TOT) as the measurement reference method. The TOT method is described in section 2.

Note 3.— Only the accuracy performance specification is needed and applied in the annual calibration procedure described in section 5 of this attachment.

Note 4.— Applicability is determined following the procedure provided in section 3 of this attachment.

Table A7-3. Performance specifications for nvPM mass instruments (nvPMmi)

<i>Performance specification</i>	<i>Value (equal to or less than)</i>	<i>Determination method</i>
Repeatability	10 µg/m ³	ISO* 6.4.5.3
Zero drift	10 µg/m ³ /hr	ISO 6.6 (for CO only)
Linearity	15 µg/m ³	ISO* 6.4.5.4
Limit of detection (LOD)	1 µg/m ³	ISO* 6.4.5.5
Rise time	2 seconds	ISO 6.3
Sampling interval	1 second	ISO 2.1.7
Accuracy (Agreement with EC mass concentration determined from TOT)	±10 per cent	Slope of the linear regression between nvPMmi mass concentration and EC mass concentration determined from TOT after calibration (Table A7-5)
Applicability	±16 per cent	Validation on aircraft turbine exhaust

2. THERMAL OPTICAL TRANSMITTANCE (TOT) METHOD

Thermal optical transmittance (TOT) shall be the measurement reference method to demonstrate conformity with the performance specifications of each make and model of the nvPMmi and to calibrate the nvPMmi. This method permits the determination of EC and organic carbon (OC) in the nvPM samples.

2.1 General

2.1.1 The TOT analyser shall be either a laboratory instrument (with a flame ionization detector (FID)) or semi-continuous instrument (with a non-dispersive infrared detector (NDIR)).

2.1.2 The TOT method shall use the temperature profile specified in Table A7-4.

Note.— *Guidance material on the TOT method is provided in the Environmental Technical Manual (Doc 9501), Volume II — Procedures for the Emissions Certification of Aircraft Engines.*

2.2 Reagents and materials

2.2.1 The following reagents shall be used:

- a) aqueous solutions of reagent grade (99 per cent or greater) sucrose, diluted with ultrapure H₂O Type I, or equivalent, to produce 0.1 to 3 mg C per millilitre solution;
- b) He — purity 5.0 (greater than 99.999 per cent);
- c) H₂ — purity 4.5 (greater than 99.995 per cent);
- d) zero air (with less than 0.2 ppm hydrocarbons);

- e) a certified mixture of 10 per cent O₂ in He; and
- f) a certified mixture of 5 per cent CH₄ in He.

2.2.2 The following material shall be used:

- a) for the laboratory instrument, a metal punch provided with the instrument for removal of 1.0 cm² or 1.5 cm² rectangular portion of filter;
- b) for the semi-continuous instrument, a metal punch provided with the instrument for removal of two 2.0 cm² circular filters;
- c) Pall Tissuquartz™ quartz fibre filters, or equivalent; and
- d) syringe of 10 microlitres.

2.2.3 Filter preparation

Depending on the instrument used, the filters shall be prepared as follows:

- a) for manual sampling and analysis, all quartz fibre filters shall be pre-fired in a muffle furnace at or greater than 550°C for 12 hours, or greater than or equal to 800°C for 1 hour to 2 hours before sampling and stored in a sealed container; or
- b) for the semi-continuous analyser, the filters for measurement shall be conditioned by performing at least one complete measurement cycle as described in Table A7-4.

Table A7-4. Required temperature profile for the TOT method analysis cycle

<i>Carrier gas</i>	<i>Temperature (°C)</i>	<i>Time at temperature (seconds)</i>
100 per cent He	310	80
	475	80
	615	80
	870	110
	550	45
10 per cent O ₂ in He	550	45
	625	45
	700	45
	775	45
	850	45
	870	60
	930	120
5 per cent CH ₄ in He	0	120

2.3 Sample preparation

2.3.1 The sample filter shall be placed on a clean aluminium foil surface.

Note.— *Isopropyl alcohol or acetone can be used to clean the foil surface. In this case, allow residual solvent to vaporize from the surface prior to use. Alternatively, the foil can be cleaned by baking in a muffle furnace prior to use.*

2.3.2 A representative portion of the filter shall be punched out. Good laboratory practice shall be used in filter handling.

2.4 Calibration and quality control

2.4.1 The temperature sensor controlling the oven temperature shall be calibrated using a traceable transfer standard within 1 year prior to any TOT analyses being conducted.

2.4.2 If the laboratory instrument is used, the FID response shall be calibrated. The calibration shall meet the following procedure:

- a) Prepare external calibration standard comprised of a sucrose solution in organic-free water.
- b) Disperse 10 microlitres of the solution on to punches from a new and clean pre-baked quartz filter.
- c) Analyse a minimum of three method blank samples and three sucrose solution samples to ensure that instrument calibration shows a percent recovery of 95 per cent to 105 per cent of the theoretical mass of C (μgC measured/ μgC dispersed).

2.4.3 If the semi-continuous instrument is used, the NDIR response shall be calibrated. The calibration shall meet the following procedure:

- a) Prepare external calibration standard comprised of a sucrose solution in organic-free water.
- b) Disperse 10 microlitres of the solution on to punches from a separate pre-conditioned “boat” filter inserted into the bottom of the quartz semi-tube.
- c) Analyse a minimum of three method blank samples and three sucrose solution samples to ensure that instrument calibration shows a percent recovery of 95 per cent to 105 per cent of the theoretical mass of C (μgC measured/ μgC dispersed).

2.4.4 If the filter analyses require more than one day, each day a single quality control check, generally using the stock sucrose solution, shall be dispersed to the filter and analysed accordingly. The results shall be within 95 to 105 per cent of the theoretical mass of C.

Note.— *The method blank is a pre-fired quartz filter without addition of sucrose but handled in the same manner.*

2.5 Measurement

The measurement shall be obtained using the following procedure:

- a) The TOT analyser shall be operated in accordance with manufacturer’s recommendations.
- b) Place sample portion into sample oven.

- c) Determine EC and OC mass in μg .

Note.— *TOT analyser results are reported in $\mu\text{g}/\text{cm}^2$ of C.*

- d) Final sample results shall always be blank-corrected:
- 1) for the laboratory instrument, the field blank consists of pre-fired quartz fibre filters handled in the same manner as the samples, except that no air is passed through the filter. EC mass loading per unit area greater than or equal to $0.3 \mu\text{g}/\text{cm}^2$ in the blank samples represents contamination;
 - 2) for the semi-continuous analyser, a measurement of the internal filter set shall be performed without any sample gas being passed through the filters.
- e) Final sample results shall always be corrected for gas phase OC artefacts. For this correction, the operating conditions (duration and flow rate) shall be identical to those used for sample collection. Depending on the instrument used, the procedure shall be as follows:
- 1) for the laboratory analyses, a sampling configuration consisting of a Teflon filter followed by a pre-fired back-up quartz filter, or a pre-fired quartz filter followed by a pre-fired back-up quartz filter, shall be employed with the backup filter analysed as prescribed in Table A7-4. Any OC found on the backup filters shall be subtracted from the OC found on sample filters;
 - 2) for the semi-continuous analyses, a Teflon filter shall be inserted in the sampling configuration prior to the analyser. Any OC found during this measurement shall be subtracted from the OC found during sample measurement.

2.6 Calculations

For the laboratory instrument:

- a) multiply the reported EC loading result ($\mu\text{g}/\text{cm}^2$) by the filter deposit area (cm^2) to calculate total mass of EC (μg) on each filter sample (W_{EC});
- b) do the same calculation as in a) for the blanks and calculate the mass found in the average blank (W_{b}); and
- c) calculate the EC mass concentration (C_{EC}) in the air volume sampled at STP conditions, V (in m^3):

$$C_{\text{EC}} = \frac{W_{\text{EC}} - W_{\text{b}}}{V} \quad (\mu\text{g}/\text{m}^3)$$

Note 1.— *The semi-continuous instrument provides the EC mass concentration as a reported result.*

Note 2.— *Guidance material on the principle of the TOT method is provided in the Environmental Technical Manual (Doc 9501), Volume II — Procedures for the Emissions Certification of Aircraft Engines.*

3. PROCEDURE TO DEMONSTRATE CONFORMITY TO PERFORMANCE SPECIFICATIONS

Note.— The procedure described in this section is used to demonstrate the conformity to the performance specifications of each make and model of the nvPMmi.

The performance specifications listed in Table A7-3 shall be demonstrated using the TOT method as described in section 2 of this attachment. The measurements shall be performed using the two following sources: a diffusion flame combustion aerosol source and a gas turbine engine exhaust nvPM source.

3.1 Measurement using a diffusion flame combustion aerosol source

3.1.1 The measurement system shall contain:

- a) a diffusion flame combustion aerosol source;
- b) a dilution system using HEPA filtered diluent to control target EC mass concentrations;
- c) a 1 µm cut-point cyclone separator upstream of the TOT instrumentation and nvPMmi;
- d) a splitter assembly meeting requirements in paragraph 4.2 d) and f) of Attachment A to this appendix;

Note.— An equivalent procedure is provided in the Environmental Technical Manual (Doc 9501), Volume II — Procedures for the Emissions Certification of Aircraft Engines.

- e) stainless steel or anti-static tubing to connect the manual quartz filter sampler, or a semi-continuous EC/OC analyser, and the nvPMmi. All tubing shall be of the same material, length and temperature from the split point to the instrument inlets; and
- f) **Recommendation.**— *If anti-static tubing is used, the tubing should meet the anti-static specification in ISO 8031.*

3.1.2 Depending on the instrument used for the TOT measurement, the following requirements shall be met:

- a) if manual sampling and laboratory analyser are used, one pre-fired, quartz filter in a stainless steel filter holder having a tapered inlet section with a $\leq 12.5^\circ$ half-angle operated at a filter face velocity less than or equal to 0.5 m/s at actual operating conditions shall be used. The diameter of the filter deposit shall be large enough to allow at least one punch to be collected from each filter. At least one punch shall be analysed from each quartz filter sample collected; or
- b) if a semi-continuous TOT analyser is used, it shall be operated at a filter face velocity of less than or equal to 0.5 m/s.

3.1.3 Measurements shall be made at tiered levels of target EC mass concentration specified in Table A7-5. Achieved EC mass concentrations shall be within 20 per cent of the target mass concentrations specified.

3.1.4 At each concentration tier level, samples shall be taken for a similar time period to establish a repeatable EC filter loading. The EC filter loading shall be $12 \pm 5 \mu\text{g}/\text{cm}^2$.

3.1.5 The averaging time as defined in ISO 9169 shall be the same as the filter collection time.

3.1.6 The average EC content determined by the TOT method shall be greater than or equal to 80 per cent of total C.

3.1.7 EC mass concentrations from the TOT method and the nvPMmi mass concentrations shall be used to determine

parameters as specified in section 4 of this attachment that demonstrate conformity to the performance specifications in Table A7-3.

3.1.8 **Recommendation.**— *Three points at 50 µg/m³ for annual calibration should be tested.*

Table A7-5. EC mass loading parameters for calibration samples

Target concentration (µg/m ³)	Approval certificate number of tests	Annual calibration number of tests
0 (blank run)	6	3
50	6	0
100	6	3
250	0	3
500	6	3

3.2 Measurement using a gas turbine engine exhaust nvPM source

3.2.1 Paragraphs 3.1.4 to 3.1.5 shall be repeated for a gas turbine engine exhaust nvPM source using the measurement system specified in paragraphs 3.1.1 c), d), e) and 3.1.2 with a dilution system using HEPA filtered diluent.

Note.— *Sufficient dilution should be used to prevent water condensation in the sample line.*

3.2.2 A minimum of four data points shall be obtained for a minimum of three different thrust levels with duplicate measurements made at one of the thrust levels using the nvPM sampling system specified above. The measurements shall be conducted at a minimum of three target concentrations, each at least a factor of 1.5 apart from the next, at least one concentration shall be above 120 µg/m³, and at least one concentration shall be below 120 µg/m³. The EC filter loading for these four data points shall be between 2.5 µg/cm² and 17 µg/cm².

3.2.3 EC mass concentrations from the TOT method and the nvPMmi mass concentrations shall be used to determine applicability as specified in Table A7-3 to demonstrate conformity to the performance specifications.

3.2.4 The engine test fuel shall be one of the aviation turbine engine fuels listed in the *Manual on Civil Aviation Jet Fuel Supply* (Doc 9977), Chapter 3, 3.2. The same fuel shall be used for the minimum four data points.

4. CALCULATION OF INSTRUMENT PERFORMANCE

4.1 The nvPMmi performance parameters zero drift, rise time and sample rate shall be determined as specified in ISO 9169, paragraphs 6.6, 6.3 and 2.1.7, respectively.

4.2 Repeatability parameter of the nvPMmi at 95 per cent confidence interval shall be determined using 6 consecutive measurements at each concentration level as:

$$s_{r_i}^2 = s_{Y_i}^2 - \Delta^2 \cdot s_{C_i}^2$$

where

$$s_{\bar{Y}_i}^2 = \frac{\sum_{j=1}^n (Y_{i,j} - \bar{Y}_i)^2}{(n - 1)}$$

s_{C_i} the standard deviation over j of the $C_{i,j}$ for level i

$Y_{i,j}$ the result of measurement by the instrument of the reference material $C_{i,j}$

$C_{i,j}$ the j^{th} instance of the reference material concentration at level i

\bar{Y}_i the average over j of the $Y_{i,j}$

n number of consecutive measurements at each concentration level (6 minimum)

Δ the slope of the regression function applied in the lack of fit test determined from the following equations:

$$E_{i,j} = Y_{i,j} - (\Gamma + \Delta \times C_{i,j})$$

$$E_i = \frac{\sum_{j=1}^n E_{i,j}}{n}$$

where

$E_{i,j}$ is the difference between $C_{i,j}$ and $Y_{i,j}$;

E_i is the average over j of the $E_{i,j}$; and

Γ is the intercept of the regression function applied in the lack of fit test.

Note.— If the repeatability so determined is negative, indicating that the variance of the measurement could not be discriminated from the variability of the reference material, the test should be repeated with additional attention given to the stability of the reference material source (diffusion flame nvPM source flow and pressure settings) and the accuracy of the determination of the reference material level (TOT method loadings and procedures). Failing this, the reproducibility can be reported as “significantly better than $\Delta \cdot s_{C_i}^2$ ”.

4.3 Linearity of the nvPMmi shall be determined as specified in ISO 9169, paragraph 6.4.5.4, however with the residual determined by the following:

$$E_i = \frac{\sum_{j=1}^n E_{i,j}}{n}$$

4.4 The LOD of the nvPMmi shall be determined as specified in ISO 9169, paragraph 6.4.5.5. If the instrument does not make a measurement when there are no particles in the sample, then a higher nvPM mass concentration, C_{LOD} , just above zero shall be used such that the instrument produces regular readings. The LOD in this case shall be determined as:

$$Y_{\text{LOD},0.95} = \bar{Y}_{\text{LOD}} - C_{\text{LOD}} + 2 \times t_{v,0.95} \times s_{\text{LOD}}$$

where

$Y_{\text{LOD},0.95}$ is the limit of detection at 95 per cent confidence interval;

\bar{Y}_{LOD} is the average of the values $Y_{\text{LOD},j}$;

C_{LOD} is the average of the values $C_{\text{LOD},j}$;

$t_{v,0.95}$ is the two sided Student's factor at 95 per cent confidence, degree $v = n-1$;

s_{LOD} is the standard deviation associated with the average Y_{LOD} .

Note.— *The reference material may not be the same in consecutive measurements taken over the averaging time. Thus, each determination of the reference material's value may be different, albeit well known as determined by the TOT method. ISO 9169 definitions are modified to accommodate such variability.*

5. CALIBRATION

5.1 The nvPMmi shall be calibrated annually using the TOT method and a system setup specified in 3.1.1 and 3.1.2 of this attachment.

5.2 Measurements shall be made at tiered levels of target EC mass concentration specified in Table A7-5. Achieved EC mass concentrations shall be within ± 20 per cent of target mass concentrations specified.

5.3 At each concentration tier level, samples shall be taken for a similar time period to establish a repeatable EC filter loading. The EC filter loading shall be $12 \pm 5 \mu\text{g}/\text{cm}^2$.

5.4 The averaging time as defined in ISO 9169 shall be the same as the filter collection time.

5.5 EC mass concentrations from the TOT method and the nvPMmi mass concentrations shall be used to establish the best fit for the data points collected from the calibration of the instruments. A linear least squares method shall be used to determine the scale factor b to adjust the nvPM mass concentrations reported by the nvPMmi as follows:

$$b = \frac{\sum x_i y_i}{\sum x_i^2}$$

where

x_i is the i^{th} nvPMmi measurement;

y_i is the TOT EC mass concentration; and

b is the slope of the best fit line.

Note 1.— *Once the b scaling factor is applied, the slope of a linear regression of the EC assays against the instrument readings adjusted by b is mathematically equal to 1.0, and the requirement on the slope in Table A7-3 will be met by definition.*

Note 2.— *Because of the expected uncertainties in the repeatability of the TOT EC assays, a repeat of the above process at the same or at a different laboratory may produce a different slope without any change in the response of the instrument. The accuracy specifications of Table A7-3 are intended to account for such variability.*

5.6 **Recommendation.**— *Prior to each annual calibration, the performance of each mass instrument should be assessed in the “as found” condition at an EC mass concentration of 100 $\mu\text{g}/\text{m}^3$ listed in Table A7-5. This assessment will allow traceability to prior calibrations of the instrument and allow comparison of existing and new calibration constants.*

**ATTACHMENT C TO APPENDIX 7. SPECIFICATIONS
AND CALIBRATION FOR THE VOLATILE PARTICLE REMOVER
AND THE nvPM NUMBER INSTRUMENT**

1. SPECIFICATIONS

1.1 VPR specifications

1.1.1 Each make and model of the volatile particle remover (VPR) shall receive a certificate from the instrument manufacturer or from another competent testing and calibration laboratory confirming that it meets the performance specifications in this attachment.

1.1.2 The VPR dilution factor (DF_2) shall meet the following requirements:

- a) DF_2 shall be adjusted to maintain particle number concentration within condensation particle counter (CPC) single count mode and to reduce sample temperature to between 10°C and 35°C at the CPC inlet.
- b) DF_2 variability shall be less than 10 per cent.

1.1.3 The heated section which evaporates volatile species shall be maintained at a temperature of 350°C ±15°C

1.1.4 If the VPR contains multiple heated stages, the additional temperature controls shall be ±15°C of operating temperatures specified by the VPR manufacturer.

1.1.5 The sample pressure control shall meet the following requirements:

- a) A pressure control device shall permit delivery of a diluted sample to the CPC within ±15 kPa of ambient (CPC exhaust) pressure.
- b) The pressure shall not exceed 105 kPa.

1.1.6 The minimum allowed particle penetration fractions of the VPR for each dilution setting shall meet the specifications listed in Table A7-6.

Table A7-6. Minimum allowed penetration fractions of the VPR at four particle diameters

Electrical mobility particle diameter, D_m	15 nm	30 nm	50 nm	100 nm
Minimum penetration fraction, $\eta_{VPR}(D_m)$	0.30	0.55	0.65	0.70

1.1.7 The VPR volatile removal efficiency (VRE) shall be such that more than 99.5 per cent of tetracontane ($CH_3(CH_2)_{38}CH_3$, greater than 95 per cent purity) particles with an inlet concentration of at least 10,000 particles/cm³ at 30 nm electrical mobility diameter are removed. This VRE shall be demonstrated when the VPR is operated at its minimum dilution setting and manufacturer's recommended operating temperature.

1.1.8 If a catalytic stripper is used in the VPR, the diluent shall contain at least 10 per cent of O₂.

1.2 VPR to CPC interface

The tube connecting the VPR outlet to the inlet of the CPC shall meet the following requirements:

- a) The material shall be electrically conductive.
- b) The tube shall have an internal diameter greater than or equal to 4 mm.
- c) The sample in the tube shall have a residence time less than or equal to 0.8 seconds.

1.3 CPC specifications

1.3.1 Each make and model of the CPC shall receive a certificate from the instrument manufacturer or from another competent testing and calibration laboratory confirming that it meets the performance specifications listed below.

1.3.2 A coincidence correction function up to a maximum of 10 per cent correction shall be allowed. The coincidence correction function shall not use any algorithm to correct for or define the counting efficiency.

1.3.3 The counting of the particles shall meet the following requirements:

- a) The counting mode shall be a single count mode. CPC use in the photometric mode is not allowed. Thus, to ensure single count mode, DF_2 shall be increased as necessary.
- b) The counting accuracy shall be of ± 10 per cent from 2 000 particles/cm³ to the upper threshold of the single particle count mode against a traceable standard (ISO 27891).
- c) The counting efficiency shall be greater than or equal to 50 per cent at 10 nm electrical mobility diameter and greater than or equal to 90 per cent at 15 nm electrical mobility diameter.
- d) The counting efficiency shall be established using an Emery oil aerosol.

1.3.4 The data acquisition rate shall be greater than or equal to 1.0 Hz for a minimum interval of 30 seconds once the engine is stabilized.

1.3.5 The particle number concentration shall be reported as particles/cm³ at STP conditions. If the reported value is not at STP conditions, the CPC absolute inlet pressure shall be measured with an accuracy better than 2 per cent so that the number concentration can be corrected to STP conditions, following manufacturer's guidelines.

1.3.6 The resolution shall be better than 0.1 particles/cm³ at concentrations below 100 particles/cm³.

1.3.7 The rise time shall be less than 4 seconds.

1.3.8 The sample flow shall be full flow. No internal flow splitting is allowed.

1.3.9 The working fluid shall be n-butanol.

1.3.10 The response shall be linear.

1.4 System requirement

The t_{90} from the inlet of the VPR through the CPC shall be equal to or less than 10 seconds.

2. CALIBRATION

2.1 VPR

Recommendation.— *Prior to each VPR calibration, the VPR should be validated “as found” at a single DF_2 setting, typical of that used for measurements on aircraft turbine engines. This validation should include the VPR dilution factor at the selected DF_2 setting, the determination of the penetration fractions and VRE.*

2.1.1 The DF_2 calibration shall meet the following requirements:

- a) The DF_2 shall be calibrated at each dilution setting of the VPR, as defined by the VPR manufacturer.
- b) **Recommendation.**— *The DF_2 calibration should be performed by a competent laboratory, using either trace gases such as CO_2 , or flow measurements.*

2.1.2 VPR particle penetration fractions calibration shall meet the following requirements:

- a) The VPR particle penetration fractions shall be measured at 350°C with solid particles of 15 nm, 30 nm, 50 nm and 100 nm electrical mobility diameters for each dilution setting of the VPR. A minimum of 5 000 particles/ cm^3 across the four particle sizes shall be delivered to the VPR. If soot is used for particle generation, then a thermal pre-treatment device heated to 350°C may be needed to deliver only nvPMP to the VPR.
- b) Particle concentrations shall be measured upstream and downstream of the VPR with a CPC that has at least 90 per cent counting efficiency for particles of an electrical mobility diameter greater than or equal to 15 nm.
- c) The VPR penetration fractions shall be determined as follows:

$$\eta_{\text{VPR}}(D_m) = \frac{DF_2 \times N_{\text{out}}(D_m)}{N_{\text{in}}(D_m)}$$

where

$N_{\text{in}}(D_m)$ is the upstream particle number concentration for particles of D_m ; and

$N_{\text{out}}(D_m)$ is the downstream particle number concentration for particles of D_m .

- d) $N_{\text{in}}(D_m)$ and $N_{\text{out}}(D_m)$ shall be referenced to the same T and P conditions.
- e) **Recommendation.**— *The VPR should be calibrated as a complete unit.*

2.1.3 VPR VRE

- a) The VRE shall be determined with a CPC that has at least 90 per cent counting efficiency for particles of an electrical mobility diameter greater than or equal to 15 nm, as follows:

$$\text{VRE}(D_{30}) = 100 \times \left[1 - \frac{DF_2 \times N_{\text{out}}(D_{30})}{N_{\text{in}}(D_{30})} \right]$$

where

VRE(D_{30}) is the VRE for particles of D_{30} ;

$N_{\text{in}}(D_{30})$ is the upstream particle number concentration for particles of D_{30} ;

$N_{\text{out}}(D_{30})$ is the downstream particle number concentration for particles of D_{30} ; and

D_{30} is the particle electrical mobility diameter.

- b) $N_{\text{in}}(D_{30})$ and $N_{\text{out}}(D_{30})$ shall be referenced to the same T and P conditions.

2.2 CPC calibration

2.2.1 The CPC calibration shall be traceable to a standard calibration method (ISO 27891): by comparison the response of the CPC under calibration with that of a calibrated aerosol electrometer when simultaneously sampling electrostatically classified calibration particles.

2.2.2 **Recommendation.**— *Prior to each CPC calibration, the CPC should be validated (“as found”).*

2.2.3 The calibration and validation shall be performed using the procedures described below:

- a) The CPC’s detection efficiency shall be calibrated with particles of 10 and 15 nm electrical mobility diameter. The CPC shall have a counting efficiency of greater than or equal to 50 per cent at 10 nm and greater than or equal to 90 per cent at 15 nm.
- b) The calibration aerosol shall be Emery oil.

ATTACHMENT D TO APPENDIX 7. SPECIFICATIONS FOR ADDITIONAL DATA

As required in 3.2 of Appendix 7, the data in Tables A7-7 and A7-8 shall be provided.

Table A7-7. Ambient nvPM requirements

<i>Data required</i>	<i>Unit</i>
Ambient nvPM mass concentration ($\text{nvPM}_{\text{mass_STP}}$)	$\mu\text{g}/\text{m}^3$
Ambient nvPM number concentration ($\text{DF}_2 \times \text{nvPM}_{\text{num_STP}}$)	$\text{particles}/\text{cm}^3$

Table A7-8. nvPM sampling system and measurement parameter requirements

<i>Parameter</i>	<i>Unit</i>
Probe inlet temperature ($T_{\text{engine_exit}}$) (Equivalent to performance-predicted engine exit exhaust gas temperature T_{EGT})	$^{\circ}\text{C}$
Measured Diluter 1 inlet temperature (T_1)	$^{\circ}\text{C}$
Individual flow rates (Measured Section 3 and Section 4; practical estimation Section 1, Section 2)	slpm
Individual pipe inner diameters for Sections 1 to 4	mm
Individual lengths for Sections 1 to 4	m
Individual pipe wall temperatures for Sections 1 to 4	$^{\circ}\text{C}$
Section 1 total angle of sampling tube bend(s)	degrees
Cyclone separator D_{50} cutpoint (manufacturer specification)	nm
Cyclone separator sharpness (manufacturer specification)	decimal fraction
Diluter 1 four penetration values (Attachment A, Table A7-2)	decimal fraction
VPR calibration four penetration values (Attachment C, Table A7-6)	decimal fraction
CPC calibration two counting efficiencies	decimal fraction
First stage dilution factor, DF_1	
Second stage (VPR) dilution factor, DF_2	
Particle mass concentration corrected for DF_1 : $\text{DF}_1 \times \text{nvPM}_{\text{mass_STP}}$	$\mu\text{g}/\text{m}^3$
Particle number concentration corrected for DF_1 and DF_2 : $\text{DF}_1 \times \text{DF}_2 \times \text{nvPM}_{\text{num_STP}}$	$\text{particles}/\text{cm}^3$

ATTACHMENT E TO APPENDIX 7. PROCEDURES FOR SYSTEM OPERATION

1. COLLECTION PART AND GAS LINE LEAKAGE CHECK

1.1 Leakage check procedure

Prior to an engine test series, the Collection Part and the GL shall be checked for leakage using the following procedure:

- a) Isolate the GL from the nvPM measurement part using Isolation Valve 1, the P₁ pressure control valve and, if installed, the optional shut-off valve.
- b) Isolate the probe and the analysers.
- c) Connect and operate a vacuum pump to verify the leakage flow rate.
- d) The vacuum pump shall have a no-flow vacuum capability of –75 kPa with respect to atmospheric pressure; its full-flow rate shall not be less than 26 L/min at standard temperature and pressure.

1.2 Leakage check requirement

The leakage flow rate shall be less than 0.4 slpm.

2. COLLECTION PART AND GAS LINE CLEANLINESS CHECK

This check is only performed if using the full gaseous nvPM EI calculation method.

2.1 Cleanliness check procedure

The Collection Part and GL shall be checked for cleanliness using the following procedure:

- a) Isolate the GL from the nvPM measurement part using Isolation Valve 1 and the P₁ pressure control valve.
- b) Isolate the GL from the probe and connect that end of the sampling line to a source of zero gas.
- c) Warm the system up to the operational temperature needed to perform HC measurements.
- d) Operate the sample flow pump and set the flow rate to that used during engine emission testing.
- e) Record the HC analyser reading.

2.2 Cleanliness check requirement

2.2.1 The HC reading shall not exceed 1 per cent of the engine idle emission level or 1 ppm (both expressed as carbon), whichever is the greater.

2.2.2 **Recommendation.**— *It is recommended to monitor the inlet air quality at the start and end of an engine test and at least once per hour during a test. If HC levels are considered significant, then they should be taken into account.*

3. TRANSFER PART CLEANLINESS/LEAKAGE CHECK

Note 1.— Cleanliness checks can fail due to contaminated transfer part components or leaks in the transfer and/or measurement parts.

Note 2.— A system leakage will result in ambient air particles drawn into the system.

3.1 Cleanliness/leakage check procedure

3.1.1 Prior to an engine test series, the transfer part shall be checked for cleanliness and leaks using the following procedure:

- a) Flow filtered diluent through Diluter 1 with Isolation Valve 1 closed.
- b) The flow rates in each Splitter 2 path shall be equal to those used during engine testing.
- c) Set the DF₂ to the lowest setting of the VPR.

3.1.2 When the measured nvPM mass and number concentrations are stable, record data for a minimum of 30 seconds.

Note.— The flow schematic for the transfer part cleanliness check is shown in Figure A7-4

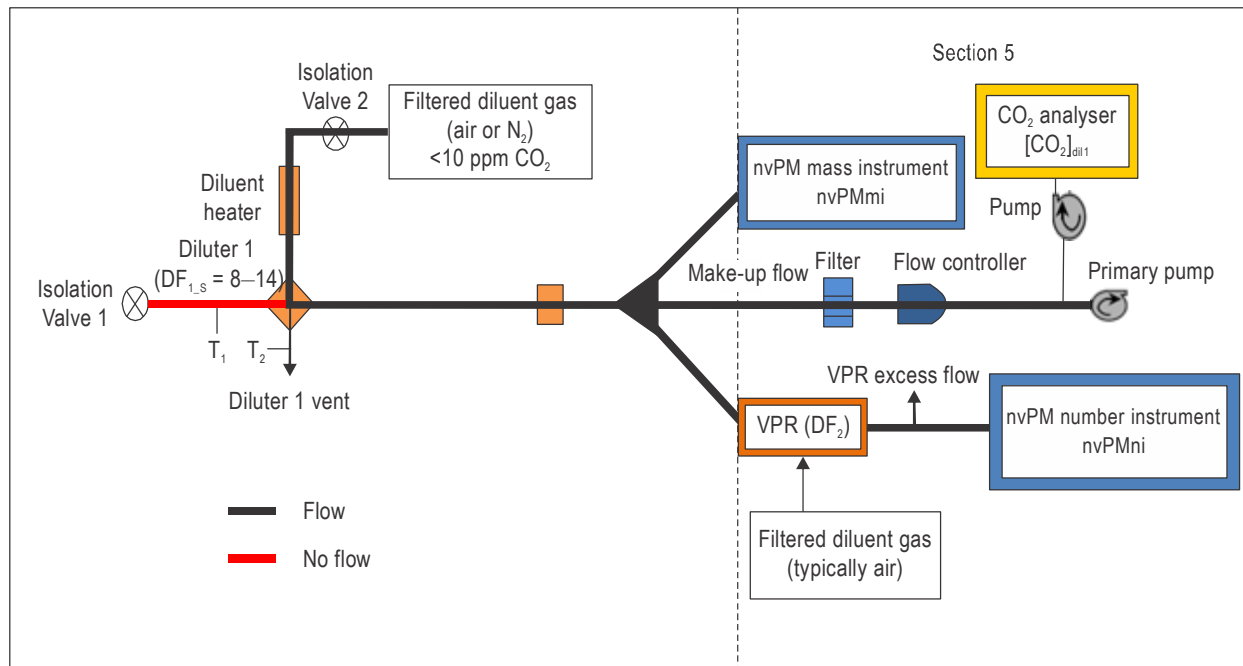

Figure A7-4. Flow schematic for the transfer part cleanliness check

3.2 Cleanliness/leakage check requirement

3.2.1 The 30 seconds averaged nvPM mass concentration ($\text{nvPM}_{\text{mass_STP}}$) shall be less than $1\ \mu\text{g}/\text{m}^3$.

3.2.2 The 30 seconds averaged nvPM number concentration ($\text{nvPM}_{\text{num_STP}}$) shall be less than $2.0\ \text{particles}/\text{cm}^3$.

3.2.3 **Recommendation.**— *If the cleanliness check fails, the system should be first inspected for leakage. If no leaks are detected, the cyclone separator collection reservoir should be inspected and cleaned. If the cleanliness check still fails, segments of the sampling system may need cleaning or replacement.*

4. COLLECTION PART BACK-PURGING

In order to maintain the Section 1 sampling probes and lines clear of unburned fuel, Section 1 shall be back-purged during engine start-up and shutdown as depicted in Figure A7-5.

5. AMBIENT nvPM MEASUREMENT

5.1 General

5.1.1 Ambient nvPM mass and number concentrations representative of engine air inlet shall be obtained before and after an engine test and reported as the average of these two measurements.

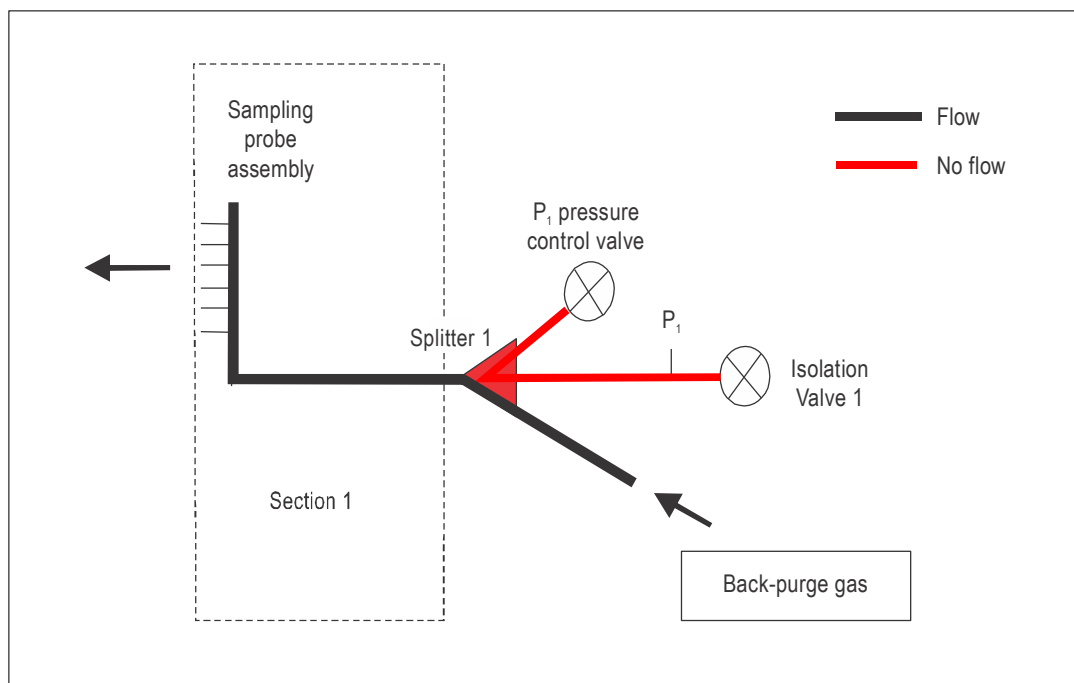

Figure A7-5. Flow schematic for Section 1 back-purge

5.1.2 **Recommendation.**— For an enclosed test cell, to achieve representativeness, it is recommended that the ambient particle measurements are obtained while the engine is running. The first ambient measurement should be obtained a minimum of five minutes after engine start-up.

5.2 Ambient nvPM sampling procedure

The ambient nvPM mass and number concentrations representative of engine air inlet shall be sampled by either:

5.2.1 Method 1: Sampling through Diluter 1 vent

The nvPM sampling and measurement system shall be used to sample through the Diluter 1 vent.

When sampling through the Diluter 1 vent the following procedure shall be used:

- Turn off the diluent flow supply to Diluter 1 by closing Isolation Valve 2 and ensure that Isolation Valve 1 is closed.
- Recommendation.**— The diluent heater should be protected from overheating when the diluent flow is turned off.
- Ensure flow rates in each Splitter 2 flow path are equal to those to be used during engine testing.
- When the measured nvPM mass and number concentrations are stable, record data for a minimum of three minutes.

Note.— The flow schematic for the Method 1 ambient nvPM measurement is shown in Figure A7-6.

This setup shall only be used if the vent exhaust location is representative of engine inlet air.

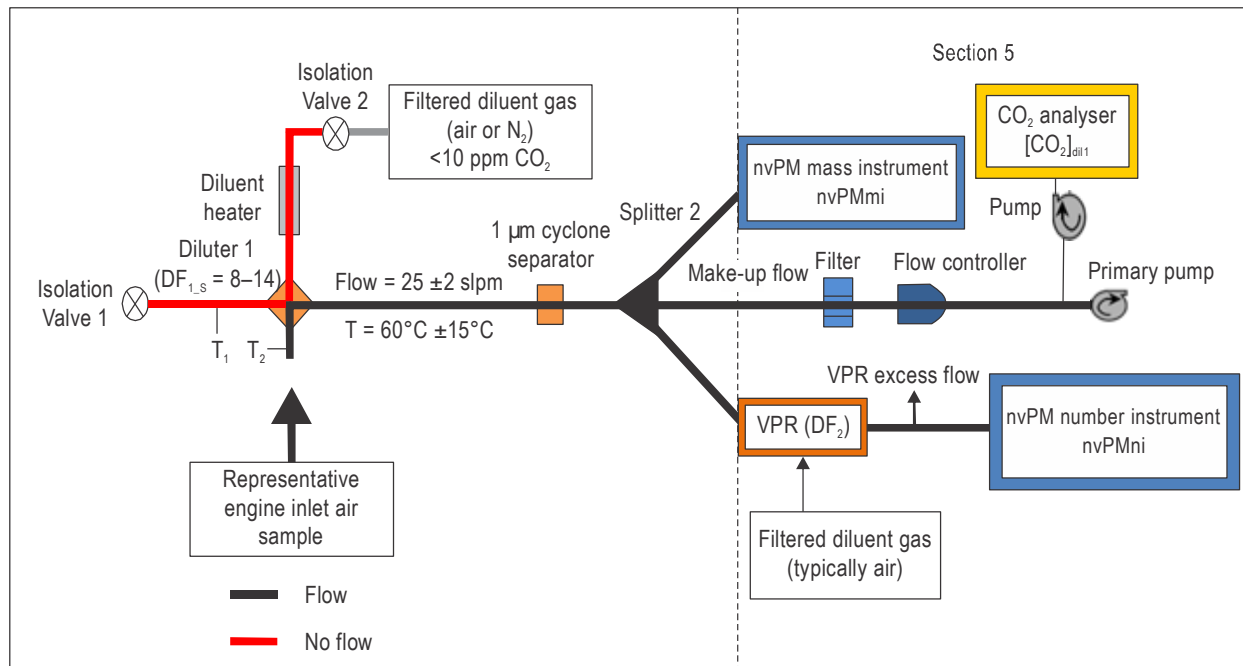

Figure A7-6. Flow schematic for ambient particle air measurement

5.2.2 Method 2: An additional nvPM measurement system

5.2.2.1 An additional ambient nvPM sampling and measurement system shall meet the following requirements:

- The ambient nvPM sampling system shall conform to Section 3 and Section 4 sampling system requirements in Attachment A to this appendix.
- The nvPMmi, VPR and nvPMni shall comply with Attachments B and Attachment C to this appendix.
- The ambient nvPM sampling system inlet shall be located within 50 m of the engine intake plane.

5.2.2.2 When sampling with an additional nvPM sampling and measurement system, the following procedure shall be used:

- Ensure flow rates in each Splitter 2 path are equal to those to be used during engine testing.
- When the measured nvPM mass and number concentrations are stable, record data for a minimum of three minutes.

5.3 Ambient particle measurement requirement

5.3.1 The three minutes averaged nvPM mass concentration ($\text{nvPM}_{\text{mass_STP}}$) and nvPM number concentration corrected for DF_2 ($\text{DF}_2 \times \text{nvPM}_{\text{num_STP}}$) shall be reported.

Note.— The ambient level of nvPM mass concentration may be below the LOD of the nvPMmi.

5.3.2 **Recommendation.**— *The average nvPMni concentration value corrected for DF_2 should be greater than 10 times the value measured for the cleanliness check. If this check fails, the system operation should be verified (valve positions, flow rates, pressures and temperatures) and the measurement should be repeated.*

5.3.3 **Recommendation.**— *If ambient nvPM levels are considered significant, then they should be taken into account.*

6. VPR DILUTION FACTOR CALIBRATION CHECK

6.1 The VPR dilution factor (DF_2) anticipated during the engine test shall be checked using the following setup:

- a) a CO₂ gas analyser compliant with Attachment B to Appendix 3;
- b) a certified, high concentration CO₂ gas with purity 2.0 (greater than 99.0 per cent) CO₂;

Note.— *Guidance material is provided in the Environmental Technical Manual (Doc 9501), Volume II — Procedures for the Emissions Certification of Aircraft Engines.*

- c) connect the CO₂ gas analyser to the outlet of the VPR with a tee fitting to prevent over pressurization of CO₂ sample;
- d) connect the high concentration CO₂ gas to the inlet of the VPR using a tee fitting and flow control valve to provide a VPR inlet pressure as on engine test;
- e) allow the sample at the inlet of the VPR to have the same flow rate and pressure as used during an engine test.

Note.— *The flow schematic for the VPR dilution factor check is shown in Figure A7-7.*

6.2 The VPR dilution factor (DF_2) shall be checked using the following procedure:

- a) Warm up the VPR and ensure operating temperatures are reached.
- b) Check that the VPR inlet is pulling a sample flow.
- c) Warm-up the CO₂ analyser accordingly and prepare for data logging.
- d) Apply appropriate zero calibration gas to the CO₂ analyser and make any necessary instrument adjustments.
- e) Apply appropriate calibration gas at a nominal 90 per cent FS concentration to the CO₂ analyser to span the ranges to be used, and adjust and record gain settings accordingly.
- f) Ensure the sample flow to the CO₂ analyser is adequate (a pump may be required upstream of the CO₂ analyser).
- g) Flow the high concentration CO₂ gas to the inlet of the VPR, ensuring that there is excess flow at the vent upstream of the VPR inlet.
- h) Set the VPR to a dilution factor setting.
- i) Adjust the flow control valve at the VPR inlet, creating a pressure drop to simulate the sub-ambient sample pressure at the VPR inlet during an engine test nvPMni measurement operation.

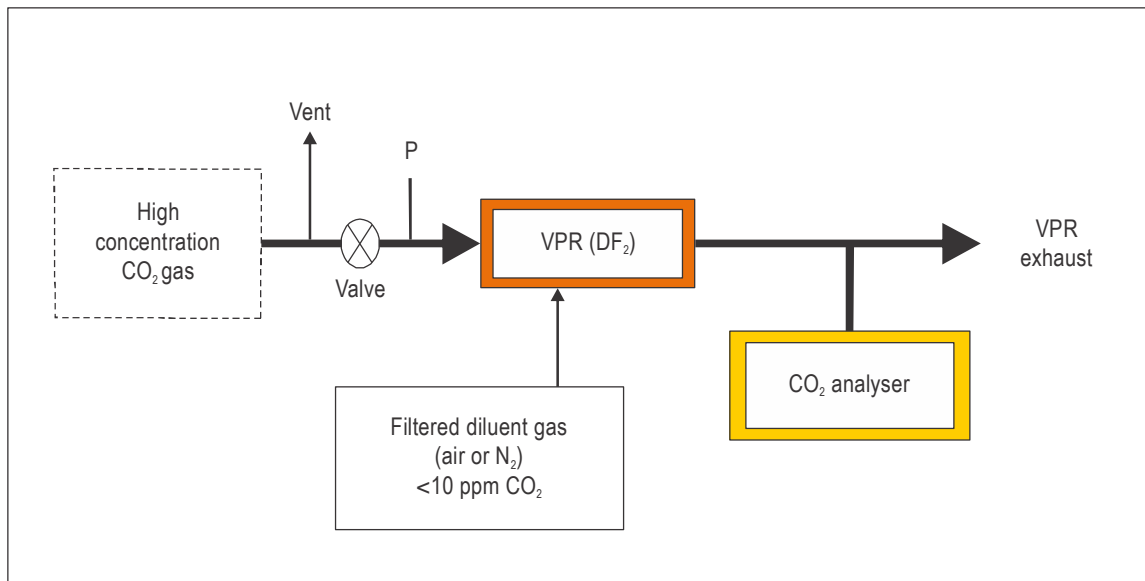

Figure A7-7. VPR dilution factor check setup

- j) Sample the VPR exhaust flow with the CO₂ gas analyser.
- k) When the CO₂ gas analyser reading is stable, record a minimum of seven CO₂ concentration data points within a three-minute period and calculate the mean.
- l) Calculate the mean DF₂ value as a ratio of the mean of CO₂ measurements and the certified CO₂ gas concentration.
- m) Repeat paragraph 6.2 h) to 6.2 l) to above for each VPR dilution setting to be used during engine testing.

6.3 Calculated DF₂ mean values shall be compared against the results of a competent laboratory calibration. If the difference is:

- a) less than or equal to ±10 per cent, DF₂ values from a competent laboratory calibration shall be used.
- b) greater than ±10 per cent, the VPR DF₂ values shall be redetermined from calibration by a competent laboratory.

Note.— Guidance material on the use of an equivalent procedure is provided in the Environmental Technical Manual (Doc 9501), Volume II — Procedures for the Emissions Certification of Aircraft Engines.

APPENDIX 8. PROCEDURES FOR ESTIMATING NON-VOLATILE PARTICULATE MATTER SYSTEM LOSS CORRECTIONS

Note 1.— The procedures specified in this appendix are concerned with the determination of non-volatile particulate matter (nvPM) sampling and measurement system loss correction factors, excluding the Collection Part thermophoretic losses which are included in Appendix 7 data reporting.

Note 2.— Implementation of the nvPM sampling and measurement system requires a long sample line of up to 35 m and includes several sampling and measurement system components, which can result in significant particle loss on the order of 50 per cent for nvPM mass and 90 per cent for nvPM number. The particle losses are size dependent and hence are dependent on engine operating condition, combustor technology and possibly other factors. The procedures specified in this appendix allow for an estimation of the particle losses.

Note 3.— The method in this appendix uses data and measurements as specified in Appendix 7 and attachments to Appendix 7. Symbols and definitions not defined in this appendix are defined in Appendix 7 and attachments.

1. GENERAL

1.1 Within the nvPM sampling and measurement system, particles are lost to the sampling system walls by deposition mechanisms. These losses are both size dependent and independent. The size independent Collection Part thermophoretic loss is specified in Appendix 7, 6.2.1.

1.2 The overall nvPM sampling and measurement system particle loss excluding the Collection Part thermophoretic loss is referred to as system loss.

1.3 The nvPM size distribution needs to be taken into consideration because the particle loss mechanisms are particle size dependent. These particle size dependent losses are quantified in terms of the fraction of particles of a given size that penetrate through the sampling and measurement system.

2. DEFINITIONS, ACRONYMS, AND SYMBOLS

2.1 Definitions

Where the following expressions are used in this appendix, they have the meanings ascribed to them below:

Aerodynamic diameter of a particle. The diameter of an equivalent sphere of unit density (1 g/cm^3) with the same settling velocity as the particle in question, also referred to as “aerodynamic diameter”.

Competent laboratory. A testing and calibration laboratory which establishes, implements and maintains a quality system appropriate to the scope of its activities, in compliance with the International Organization for Standardization standard ISO/IEC 17025:2005, as amended from time to time, or equivalent standard and for which the programme for calibration of equipment is designed and operated so as to ensure that calibrations and measurements made by the laboratory are traceable to the International System of Units (SI). Formal accreditation of the laboratory to ISO/IEC 17025:2005 is not required.

Cyclone separator. Separation of particles larger than a prescribed aerodynamic diameter via rotational and gravitational means. The specified cut-point aerodynamic diameter is associated with the percent of particles that penetrate through the cyclone separator.

Electrical mobility diameter of a particle. The diameter of a sphere that moves with exactly the same mobility in an electrical field as the particle in question.

Non-volatile particulate matter (nvPM). Emitted particles that exist at a gas turbine engine exhaust nozzle exit plane that do not volatilize when heated to a temperature of 350°C.

Particle loss. The loss of particles during transport through a sampling or measurement system component or due to instrument performance. Sampling and measurement system loss is due to various deposition mechanisms, some of which are particle size dependent.

Particle mass concentration. The mass of particles per unit volume of sample.

Particle mass emission index. The mass of particles emitted per unit of fuel mass used.

Particle number concentration. The number of particles per unit volume of sample.

Particle number emission index. The number of particles emitted per unit of fuel mass used.

Particle size distribution. A list of values or a mathematical function that represents particle number concentration according to size.

Penetration fraction. The ratio of particle concentration downstream and upstream of a sampling system element.

2.2 Acronyms

CPC	Condensation particle counter
EENEP	Engine exhaust nozzle exit plane
nvPMmi	Non-volatile particulate matter mass instrument
nvPMni	Non-volatile particulate matter number instrument
nvPM	Non-volatile particulate matter (<i>see</i> definition)
slpm	Standard litres per minute (litres per minute at STP)
STP	Instrument condition at standard temperature 0°C and pressure 101.325 kPa
VPR	Volatile particle remover

2.3 Symbols

C_c	$1 + \frac{2\lambda}{D_m} \times (1.165 + 0.483 \times e^{-\frac{0.997D_m}{2\lambda}})$, dimensionless Cunningham slip correction factor
D	$\frac{k_B \times (273.15 + T_i) \times C_c}{3 \times \pi \times \mu \times D_m \times 10^{-4}} \times 10^7$, the particle diffusion coefficient, cm^2/s
DF_1	First stage dilution factor
DF_2	Second stage (VPR) dilution factor as per calibration
D_m	nvPM particle diameter, refers to the electrical mobility diameter except for the cyclone separator where the particle diameter is the aerodynamic diameter, nm
D_{mg}	Geometric mean diameter of nvPM size distribution, nm
δ	Sum of the square of relative differences between measured and calculated dilution corrected nvPM mass and number concentrations
EI_{mass}	nvPM mass emission index corrected for thermophoretic losses and for fuel composition, in milligrams/kg fuel
EI_{num}	nvPM number emission index corrected for thermophoretic losses and for fuel composition, in number/kg fuel
$f_{ign}(D_m)$	Lognormal distribution function with parameters of geometric standard deviation, σ_g , and geometric mean diameter, D_{mg}
$f_N(D_m)$	The EENEP particle number lognormal distribution function
ID_i	Inner diameter of the i^{th} segment of the sampling line, mm
k_B	1.3806×10^{-16} , Boltzmann constant, $(\text{g} \cdot \text{cm}^2)/(\text{s}^2 \cdot \text{K})$
$k_{SL_{mass}}$	EI_{mass} correction factor for system loss without Collection Part thermophoretic loss correction
$k_{SL_{num}}$	EI_{num} correction factor for system loss without Collection Part thermophoretic loss correction
k_{thermo}	Collection Part thermophoretic loss correction factor, specified in Appendix 7, 6.2.1
λ	$67.3 \times \left(\frac{273.15 + T_i}{296.15}\right)^2 \times \left(\frac{101.325}{P_i}\right) \times \left(\frac{406.55}{T_i + 383.55}\right)$, the carrier gas mean free path, nm
μ	Carrier gas viscosity, $\text{g}/\text{cm} \cdot \text{s}$
$nvPM_{num_EP}$	Estimated engine exhaust nozzle exit plane nvPM number concentration not corrected for Collection Part thermophoretic losses
$nvPM_{mass_STP}$	Diluted nvPM mass concentration at instrument STP condition, $\text{micrograms}/\text{m}^3$
$nvPM_{num_STP}$	Diluted nvPM number concentration at instrument STP condition, $\text{number}/\text{cm}^3$
$\eta_{mass}(D_m)$	Overall sampling and measurement system penetration fraction for the nvPMmi without Collection Part thermophoretic losses at electrical mobility particle size D_m

$\eta_{\text{num}}(D_m)$	Overall sampling and measurement system penetration fraction for the nvPM _{ni} without Collection Part thermophoretic losses at electrical mobility particle size D_m
$\eta_i(D_m)$	Penetration fraction for the i^{th} component of the sampling and measurement system at electrical mobility particle size D_m
$\eta_{bi}(D_m)$	Penetration fraction for the sampling line bend for i^{th} component of the sampling and measurement system at electrical mobility particle size D_m
P_i	Carrier gas pressure in the i^{th} segment of the sampling line, kPa
ρ	Assumed nvPM effective density, g/cm^3
ρ_{gas}	$\frac{29 \times P_i}{8314 \times (273.15 + T_i)}$, Carrier gas density, g/cm^3
σ_g	Assumed geometric standard deviation of lognormal distribution
Q_i	Carrier gas flow in the i^{th} segment of the sampling line, slpm
Re	$\frac{2 \times \rho_{\text{gas}} \times Q_i}{3 \times \pi \times \mu \times ID_{i1}}$, Carrier gas Reynolds number
$R_{\text{MN}}(D_m)$	Calculated ratio of the estimated nvPM mass concentration to the estimated nvPM number concentration
T_i	Carrier gas temperature in the i^{th} segment of the sampling line, °C

3. DATA REQUIRED

3.1 nvPM emissions

In order to calculate the system loss correction factors, the following concentrations as specified in Appendix 7 are needed:

- a) nvPM mass concentration: $\text{nvPM}_{\text{mass_STP}}$;
- b) nvPM number concentration: $\text{nvPM}_{\text{num_STP}}$.

3.2 Other information

Additional information listed in Attachment D to Appendix 7 is required to perform the calculation procedure.

4. nvPM SYSTEM LOSS CORRECTION METHODOLOGY AND CALCULATION PROCEDURE

4.1 Overview

Note.— An overview diagram of the methodology for estimating the system loss correction factors is shown in Figure A8-1.

4.1.1 The system loss correction factors shall be estimated based on the following assumptions: EENEP nvPM is represented by a constant value of nvPM effective density, a lognormal distribution, a fixed value of geometric standard deviation, no coagulation, limiting the nvPM mass and number concentrations as described in the calculation method limitations section, and a minimum summation particle size cut-off of 10 nm.

4.1.1.1 The system loss correction methodology shall use a particle effective density of 1 g/cm³.

4.1.1.2 A mono-modal lognormal distribution with a geometric standard deviation of 1.8 shall be used in the system loss correction methodology.

4.1.1.3 The system loss correction methodology does not consider reduction in nvPM number concentration due to coagulation.

4.1.1.4 If the EENEP nvPM number concentration calculated using:

$$k_{SL_num} \times k_{thermo} \times DF_1 \times DF_2 \times nvPM_{num_STP}$$

is greater than 10⁸ particles/cm³, coagulation may occur and shall be reported to the certifying authority.

Note 1.— The system loss correction methodology does not consider penetration drift. This is not considered significant for Appendix 7-compliant nvPM measurement systems.

Note 2.— An illustration of the iterative calculation procedure is shown in Figure A8-2.

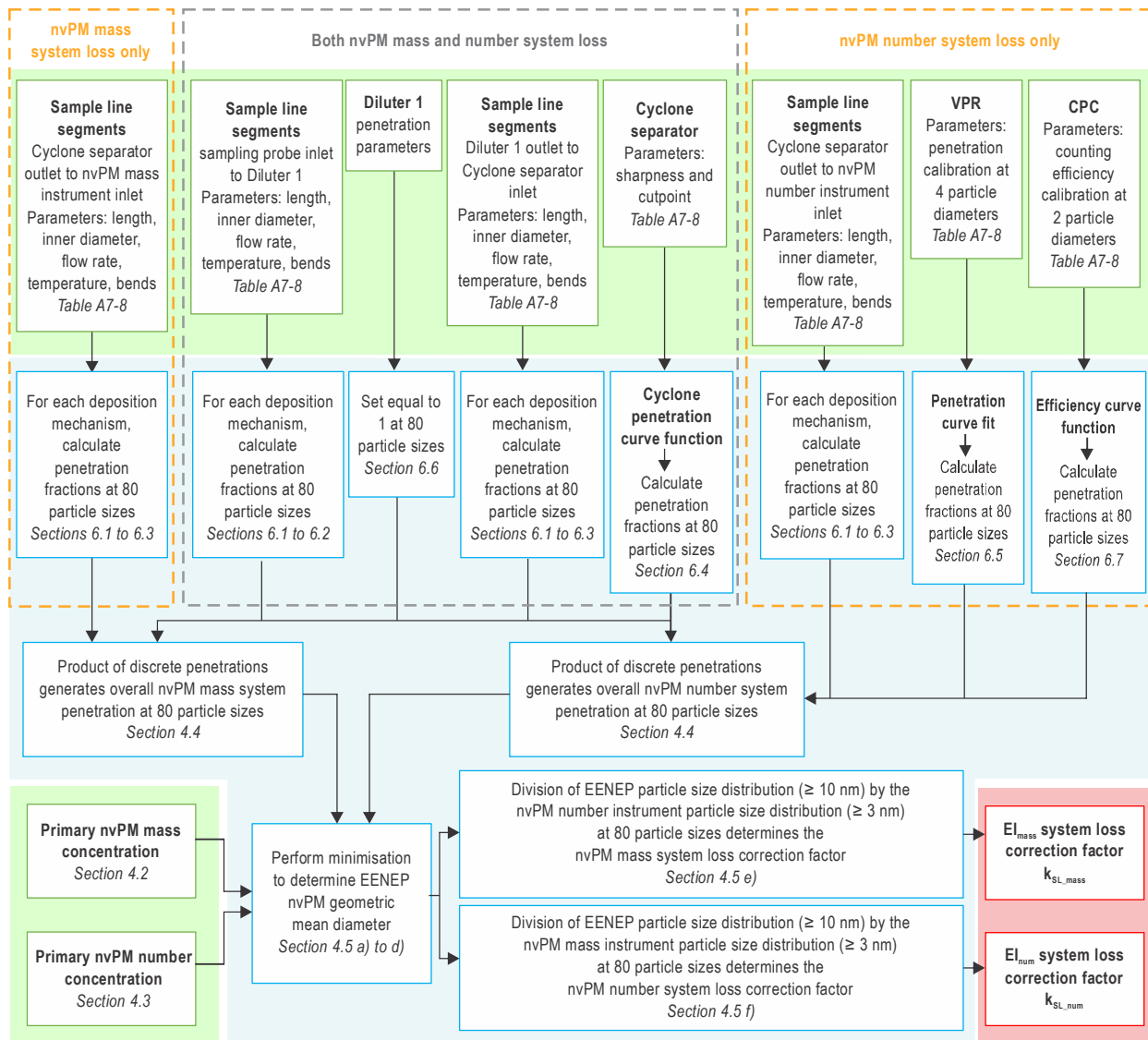

Figure A8-1. Flow block diagram of the nvPM system loss correction methodology. The green blocks show model input parameters, the blue blocks shows model calculations and the red outline blocks shows calculation output system loss correction factors.

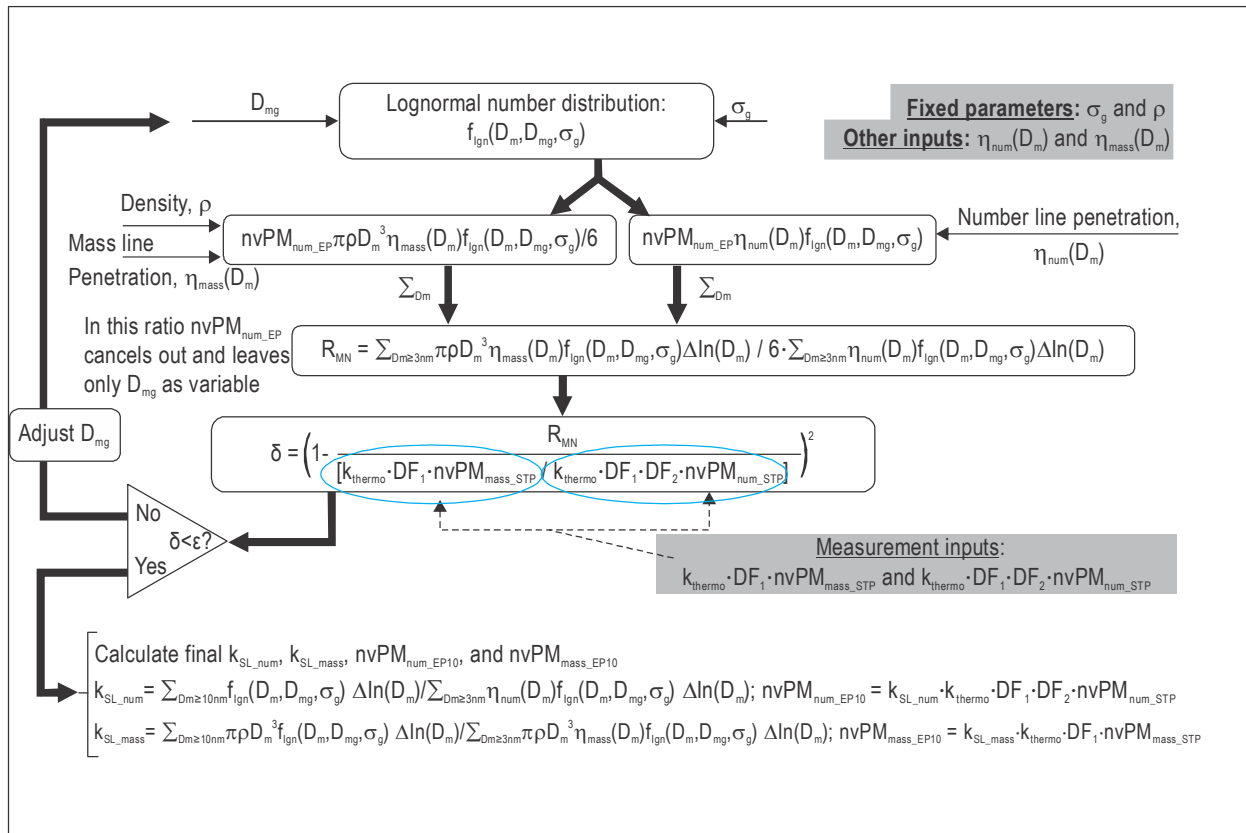

Figure A8-2. Iterative calculation procedure diagram for determination of system loss correction factors

4.2 Primary nvPM mass concentration

The primary nvPM mass concentration ($nvPM_{mass}$) is calculated using the following equation as defined in Appendix 7:

$$nvPM_{mass} = k_{thermo} \times DF_1 \times nvPM_{mass_STP}$$

4.3 Primary nvPM number concentration

The primary nvPM number concentration ($nvPM_{num}$) represents the number of particles per unit volume of engine exhaust sample corrected for the first stage dilution factor (DF_1) and second stage dilution factor (DF_2) and the Collection Part thermophoretic particle loss. It is calculated using the following equation:

$$nvPM_{num} = k_{thermo} \times DF_1 \times DF_2 \times nvPM_{num_STP}$$

4.4 nvPM penetration functions

4.4.1 The sampling system penetration fraction is a product of the individual penetration and counting efficiency functions. Table A8-1 provides the required nvPM penetration and counting efficiency functions and shall be calculated using the procedures described in Section 6.

4.4.2 The sampling system penetration for nvPMmi for a particle of diameter D_m is:

$$\eta_{\text{mass}}(D_m) = \eta_1 \times \eta_{b1} \times \eta_2 \times \eta_{b2} \times \eta_3 \times \eta_{b3} \times \dots \times \eta_{\text{dil}} \times \eta_{\text{cyc}}$$

4.4.3 The sampling system penetration for nvPMni for a particle of diameter D_m is:

$$\eta_{\text{num}}(D_m) = \eta_1 \times \eta_{b1} \times \eta_2 \times \eta_{b2} \times \eta_3 \times \eta_{b3} \times \dots \times \eta_{\text{dil}} \times \eta_{\text{cyc}} \times \eta_{\text{VPR}} \times \eta_{\text{CPC}}$$

4.4.4 The size independent nvPM mass and number sampling system thermophoretic penetration is:

$$\eta_{\text{thermo}} = \eta_{\text{th1}} \times \eta_{\text{th2}} \times \eta_{\text{th3}} \times \dots$$

Note.— The Collection Part thermophoretic loss, k_{thermo} , is specified in Appendix 7, 6.2.1 and is not included in this calculation.

Table A8-1. Required nvPM Sampling and Measurement system component penetration fractions

Symbol	Description of nvPM Sampling and Measurement system particle transport functions
$\eta_i(D_m)$	Diffusional penetration fraction of i^{th} segment of sampling system
$\eta_{bi}(\Theta_i)$	Penetration fraction due to bends in i^{th} segment of sampling system
$\eta_{\text{th}i}$	Penetration fraction due to thermophoresis in i^{th} segment of sampling system
$\eta_{\text{dil}}(D_m)$	Diluter 1 penetration fraction
$\eta_{\text{cvc}}(D_m)$	Cyclone separator penetration fraction
$\eta_{\text{VPR}}(D_m)$	VPR penetration fraction
$\eta_{\text{CPC}}(D_m)$	CPC counting efficiency

4.5 Calculation of system loss correction factors

System loss correction factors for nvPM mass ($k_{\text{SL}_{\text{mass}}}$) and nvPM number ($k_{\text{SL}_{\text{num}}}$) shall be calculated using the iterative procedure:

- a) Estimate an initial value of the geometric mean diameter using the equation:

$$D_{\text{mg}} = \sqrt[3]{\frac{6 \times \text{DF}_1 \times \text{nvPM}_{\text{mass_STP}}}{\pi \times \rho \times \text{DF}_1 \times \text{DF}_2 \times \text{nvPM}_{\text{num_STP}}}} \times 10^3$$

Note.— The arithmetic mean diameter calculated by the equation above provides the initial value of the geometric mean diameter, D_{mg} , for the iterative procedure. Using the units defined for the inputs, the calculated particle diameter will be in nm.

- b) Using the value of D_{mg} from step a), calculate the estimated nvPM mass to nvPM number ratio, $R_{MN}(D_{mg})$, using the equation:

$$R_{MN}(D_{mg}) = \frac{\sum_{D_m > 3nm}^{1000nm} \eta_{mass}(D_m) \times \frac{\pi \rho D_m^3}{6} \times e^{-\frac{1}{2} \left(\frac{\ln(D_m) - \ln(D_{mg})}{\ln(\sigma_g)} \right)^2} \times \Delta \ln(D_m)}{\sum_{D_m > 3nm}^{1000nm} \eta_{num}(D_m) \times e^{-\frac{1}{2} \left(\frac{\ln(D_m) - \ln(D_{mg})}{\ln(\sigma_g)} \right)^2} \times \Delta \ln(D_m)}$$

where the exponential functions come from the lognormal distribution function,

$$f_{lgn}(D_m) = \frac{1}{\sqrt{2\pi} \ln(\sigma_g)} \times e^{-\frac{1}{2} \left(\frac{\ln(D_m) - \ln(D_{mg})}{\ln(\sigma_g)} \right)^2}$$

$\Delta \ln(D_m) = \frac{1}{n} \times \frac{1}{\log_{10}(e)}$, is the width of a size bin in base natural logarithm; e is the Euler's number, and n is the number of particle size bins per decade.

- c) Determine the squared relative difference, δ , between the measured and estimated nvPM mass to number ratio using:

$$\delta = \left\{ 1 - \frac{R_{MN}(D_{mg}) \times 10^{-9}}{[(k_{thermo} \times DF_1 \times nvPM_{mass_STP}) / (k_{thermo} \times DF_1 \times DF_2 \times nvPM_{num_STP})]} \right\}^2$$

- d) Repeat steps b) and c) by varying D_{mg} until δ reduces to less than 1×10^{-9} . The D_{mg} associated with this minimized value of δ shall be used to calculate the system loss correction factors.
- e) Calculate the nvPM mass system loss correction factor using the equation:

$$k_{SL_mass} = \frac{\sum_{D_m > 10nm}^{1000nm} D_m^3 \times e^{-\frac{1}{2} \left(\frac{\ln(D_m) - \ln(D_{mg})}{\ln(\sigma_g)} \right)^2} \times \Delta \ln(D_m)}{\sum_{D_m > 3nm}^{1000nm} \eta_{mass}(D_m) \times D_m^3 \times e^{-\frac{1}{2} \left(\frac{\ln(D_m) - \ln(D_{mg})}{\ln(\sigma_g)} \right)^2} \times \Delta \ln(D_m)}$$

Multiplying EI_{mass} by k_{SL_mass} yields nvPM emission index corrected for system loss.

- f) Calculate the nvPM number system loss correction factor using the equation:

$$k_{SL_num} = \frac{\sum_{D_m > 10nm}^{1000nm} e^{-\frac{1}{2} \left(\frac{\ln(D_m) - \ln(D_{mg})}{\ln(\sigma_g)} \right)^2} \times \Delta \ln(D_m)}{\sum_{D_m > 3nm}^{1000nm} \eta_{num}(D_m) \times e^{-\frac{1}{2} \left(\frac{\ln(D_m) - \ln(D_{mg})}{\ln(\sigma_g)} \right)^2} \times \Delta \ln(D_m)}$$

Multiplying EI_{num} by k_{SL_num} yields nvPM emission index corrected for system loss.

- g) A minimum of 80 discrete sizes in the particle size range from 3 to 1 000 nm or a minimum number of bins that will produce equivalent results as agreed by the certificating authority shall be used in this calculation.

Note 1.— For 80 discrete sizes, the number of size bins per decade, n , is 32 (see the definition for $\Delta \ln(D_m)$ above).

Note 2.— The summations to compute the system loss correction factors start at 10 nm in the numerator and 3 nm in the denominator.

Note 3.— The calculation procedure can be implemented using commercially available software programmes.

5. REPORTING AND LIMITATIONS

Note 1.— The system loss correction factor calculation method described in Appendix 8, section 4 has been shown to give acceptable results over a wide range of nvPM mass and number concentrations observed in aircraft turbine engine nvPM emissions. There are, however, ranges of nvPM mass and number concentrations that have been identified where the inputs to the analysis may lack the fidelity for the calculation method to yield quality results.

Note 2.— Any variations from the assumptions used by the calculation method as required in section 4.1.1 of this appendix can lead to variation in the system loss correction factors. Similarly, variations in the data supplied to the calculation method will result in variation in system loss correction factors. The variation in the data could be due to particle size distributions, sampling system, or instruments. In addition, sampling and measurement system artifacts, such as possible shedding from the walls when concentrations are low, may provide invalid system loss correction factor. Method limitations are due to variation within the input data rather than the calculation method.

5.1 Applicable mass concentration ranges

Note.— When raw nvPM mass concentrations at the nvPMmi (not dilution corrected) are below 3 micrograms/m³, use of this method to estimate system loss correction factors is cautioned because of the possible uncertainties with the nvPM mass concentration determination at such low values.

5.1.1 If the nvPMmi raw mass concentrations are below 3 micrograms/m³, the applicant shall confirm that the predicted EENEP D_{mg} falls within the applicable range in 5.3.

5.1.2 **Recommendation.**— For cases where calculations from this appendix or other equivalent methods do not provide reasonable values as noted in 5.3 (e.g. when the system loss methodology calculates EENEP geometric mean diameters less than 7 nm or greater than 100 nm), or when the system loss methodology does not converge, alternate means of estimating system loss correction factors for the LTO operating modes should be used, subject to the approval of the certificating authority.

Note.— There are no currently known limitations regarding high nvPM mass concentrations as long as it is verified that the nvPM mass concentration readings are within the range of the nvPMmi used.

5.2 Applicable number concentration ranges

5.2.1 If the nvPM number concentration measured at the nvPMni, corrected for dilution (both DF_1 and DF_2) and Collection Part thermophoretic loss is found to be less than or equal to the measured ambient number concentration¹, the applicant shall confirm that the predicted EENEP D_{mg} falls within the applicable range in 5.3.

1. See Appendix 7, Attachment E.

5.2.2 Recommendation.— For cases where calculations from this appendix or other equivalent methods do not provide reasonable values as noted in 5.3 (e.g. when the system loss methodology calculates EENEP geometric mean diameters less than 7 nm or greater than 100 nm), or when the system loss methodology does not converge, alternate means of estimating system loss correction factors for the LTO operating modes should be used, subject to the approval of the certifying authority.

Note.— For the nvPMni, there are no currently known limitations on low nvPM number concentrations. CPC manufacturers report the CPC LOD to be about 1 particle/cm³. High number concentration measurements are limited by the requirement for the CPC to stay in the single count mode. If the EENEP nvPM number concentrations are above 10⁸ particles/cm³, particle coagulation may be occurring. Coagulation is not considered in the system loss calculation method.

5.3 Applicable predicted geometric mean diameters

Note.— The geometric mean diameter of nvPM at EENEP from aircraft gas turbines is anticipated to be in the range of 7 to 100 nm.

5.3.1 If the system loss calculation method predicts an EENEP geometric mean diameter that is smaller than 7 nm or larger than 100 nm, and/or if the system loss calculation method predicts an EENEP geometric mean diameter whereby the convergence criterion is not met (δ is greater than 1×10^{-9}), results for k_{SL_mass} and k_{SL_num} shall be reviewed with the certifying authority.

5.3.2 Recommendation.— For cases where calculations from this appendix or other equivalent methods do not provide reasonable values (e.g. when the system loss methodology calculates EENEP geometric mean diameters less than 7 nm or greater than 100 nm), or when the system loss methodology does not converge, alternate means of estimating system loss correction factors for the LTO operating modes should be used, subject to the approval of the certifying authority.

Note.— Calculated EENEP geometric mean diameters < 20 nm will result in underestimation of system loss factors due to the minimum summation particle size cut-off. The underestimation can be significant for k_{SL_num} when EENEP $D_{mg} \leq 10$ nm.

6. PROCEDURE TO DETERMINE PENETRATION FRACTIONS OF INDIVIDUAL COMPONENTS OF THE nvPM SAMPLING AND MEASUREMENT SYSTEM

To estimate the nvPM transport efficiency for particles over a range of sizes, penetration fractions shall be calculated for each component of the nvPM sampling and measurement system, for a minimum of 80 discrete particle sizes or a minimum number of discrete particle sizes that will produce an equivalent result, as agreed by the certifying authority in the range from 3 to 1 000 nm.

Note 1.— Where continuous functions are calculated to estimate penetration fractions, these functions are not to go below zero.

Note 2.— The nvPM measurement and sampling system parameters required to perform the penetration fraction calculations in this appendix are contained in Appendix 7, Attachment D.

6.1 Segment diffusional penetration fractions

Penetration values, $\eta_i(D_m)$, for diffusional losses in sampling system segments at electrical mobility particle size D_m are calculated with the expression:

$$\eta_i(D_m) = e^{\frac{-\pi \times ID_{ti} \times L_i \times V_{d,diff}}{Q_i}}$$

where:

L_i	length of the i^{th} segment of the sampling line, m
$V_{d,diff}$	$0.0118 \times Re^{\frac{7}{8}} \times Sc^{\frac{1}{3}} \times D/ID_{ti}$, the deposition speed, cm/s
Sc	$\frac{\mu}{\rho_{gas} D} \times 10^3$, the carrier gas Schmidt number
ID_{ti}	inner diameter of the i^{th} segment of the sampling line, mm
Q_i	the carrier gas flow in the i^{th} segment of the sampling line, slpm

6.2 Segment bend penetration fractions

The bend penetration fractions are distinguished for turbulent flow, Re is greater than 5 000, and for laminar flow, Re is less than or equal to 5 000 where Re is the Reynolds number. For laminar flow (including the transition regime) the penetration due to bends in the sample transport lines for each segment at electrical mobility particle size D_m is calculated as:

$$\eta_{bi}(D_m) = 1 - 0.01745 \times Stk \times \theta_{bi}$$

For turbulent flow, the penetration due to bends in the sample transport lines shall be calculated as

$$\eta_{bi}(D_m) = e^{-0.04927 \times Stk \times \theta_{bi}}$$

where

$$Stk = \frac{Q_i \times C_c \times \rho \times D_m^2 \times 10^{-3}}{27 \times \pi \times \mu \times ID_{ti}^3}, \text{ the dimensionless Stokes number}$$

θ_{bi} total angle of bends in the of the i^{th} segment of the sampling line, degrees

6.3 Segment thermophoretic losses

Thermal gradients occurring because sample line wall temperatures are lower than gas temperatures cause additional particle deposition, thermophoretic losses, onto the sampling line surfaces. The thermophoretic losses, except for those in the Collection Part, are calculated using:

$$\eta_{thi} = \left[\frac{T_{linei} + 273.15}{T_{gasi} + 273.15} \right]^{Pr \times K_{th}} \times \left[1 + \left(\frac{T_{gasi} + 273.15}{T_{linei} + 273.15} - 1 \right) \times e^{-\frac{\pi \times ID_i \times h_{gas} \times L_i}{\rho_{gas} \times Q_i \times C_p}} \right]^{Pr \times K_{th}}$$

where

T_{gasi}	sample gas temperature in °C
T_{linei}	line wall temperature in °C
h_{gas}	carrier gas convective heat transfer coefficient (W/(m ² K))

C_p	constant pressure carrier gas specific heat (J/(kg K))
Pr	Prandtl number
K_{th}	$\frac{2 \times C_s \times C_c}{1 + 3 \times C_m \times K_n} \left[2 + \frac{1}{\left(\frac{k_{gas}}{k_p} \right) + C_t \times K_n} \right]^{-1}$, the thermophoretic coefficient
C_s	1.17, slip coefficient
C_m	1.14, soot momentum
C_t	2.18, thermal coefficient
k_{gas}	thermal conductivity of the carrier gas ($Wm^{-1}K^{-1}$)
K_n	$2\lambda/D_m$, Knudsen number
k_p	$0.2 Wm^{-1}K^{-1}$, particle thermal conductivity

Note.— The Collection Part and VPR thermophoretic losses are taken into account as specified in Appendix 7, 6.2.1 and 6.5 of this attachment. A system compliant with specifications in Appendix 7 uses instruments and segments that currently do not need to be corrected for thermophoretic losses and therefore η_{hi} will effectively be equal to 1.0.

6.4 Cyclone separator penetration function

The penetration function of the cyclone separator shall be estimated using the following expression:

$$\eta_{cyc}(D_m) = 1 - \int_{x>0}^{D_m} \frac{e^{-\frac{(\ln x - \mu_{cyc})^2}{2\sigma_{cyc}^2}}}{x\sigma_{cyc}\sqrt{2\pi}} dx$$

where

$$\begin{aligned} \mu_{cyc} & \ln(D_{50}); \text{ and} \\ \sigma_{cyc} & \ln(D_{16}/D_{84})^{0.5} \end{aligned}$$

Note 1.— Modern computer spreadsheet applications have the cumulative lognormal distribution built into the function library that could be used to generate the penetration function of the cyclone separator.

Note 2.— For most gas turbine engine applications D_m will be less than 300 nm. In such cases the cyclone separator penetration function will be effectively equal to 1.0.

6.5 VPR penetration function

Note.— A smooth function provided by the calibration laboratory that has goodness of fit results (R^2 greater than 0.95) for the four VPR calibration penetration points could be used in place of the function determined from the calculation procedure outlined below.

Particle losses in the VPR are due to both diffusion and thermophoresis. The thermophoretic factor, η_{VPRth} , is a constant. The diffusion factor, η_{VPRdi} , is determined from standard particle losses due to diffusion in a laminar flow. The total VPR penetration function shall be estimated using the expression:

$$\eta_{VPR} = \eta_{VPRth} \times \begin{cases} 1 - 5.5 \times \psi^{\frac{2}{3}} + 3.77 \times \psi & \psi < 0.007 \\ 0.819 \times e^{-11.5\psi} + 0.0975 \times e^{-70.1\psi} + 0.0325 \times e^{-179\psi} & \psi > 0.007 \end{cases}$$

where

Ψ	$\frac{D \times L_{VPR} \times 100}{Q_{VPR}}$, deposition parameter
L_{VPR}	effective length of the VPR, m
Q_{VPR}	carrier gas flow in the VPR, slpm
T_{VPR}	VPR temperature, °C
η_{VPRth}	VPR thermophoretic loss

The VPR penetration function (η_{VPR}) shall be fitted to the four measured penetration points by varying the VPR effective length (L_{VPR}) and the thermophoretic loss factor (η_{VPRth}). The fit shall be calculated by minimizing δ_{VPR} , the relative sum of squares difference between the measured VPR penetration, $\eta_{VPRmeas}$, and the calculated penetration function.

$$\delta_{VPR} = \sqrt{\sum_{D_m} \left(\frac{\eta_{VPRmeas}(D_m) - \eta_{VPR}(D_m)}{\eta_{VPRmeas}(D_m)} \right)^2}$$

A value of δ_{VPR} less than 0.08 has been shown to provide a good fit to the measured penetrations.

6.6 Diluter 1 penetration function

A constant Diluter 1 penetration, $\eta_{dil}(D_m) = 1$ shall be used for all particle sizes.

6.7 CPC counting efficiency

A continuous function for the CPC counting efficiency shall be determined using the two CPC counting efficiencies specified with a two-parameter sigmoid function using the expression:

$$\eta_{CPC} = 1 - e^{-\ln(2) \times \left[\frac{D_m - D_0}{D_{50} - D_0} \right]}$$

where

$$D_0 = \frac{\alpha_{10} D_{15} - \alpha_{15} D_{10}}{\alpha_{10} - \alpha_{15}}$$

$$D_{50} = \frac{(\alpha_{15} + 1) D_{10} - (\alpha_{10} + 1) D_{15}}{\alpha_{15} - \alpha_{10}}$$

$$\alpha_i = \frac{\ln(1 - \eta_{CPC,i})}{\ln(2)}, i = 10 \text{ nm or } 15 \text{ nm}$$

$$D_{10} = 10 \text{ nm};$$

$$D_{15} = 15 \text{ nm};$$

$\eta_{CPC,10}$, the counting efficiency at 10 nm; and

$\eta_{CPC,15}$, the counting efficiency at 15 nm.

— END —

ISBN 978-92-9258-314-9



9

789292

583149